

GEAR REDUCER

Helical Reducer

Helical - Bevel Reducer



Global Top Energy, Machinery & Plant Solution Provider

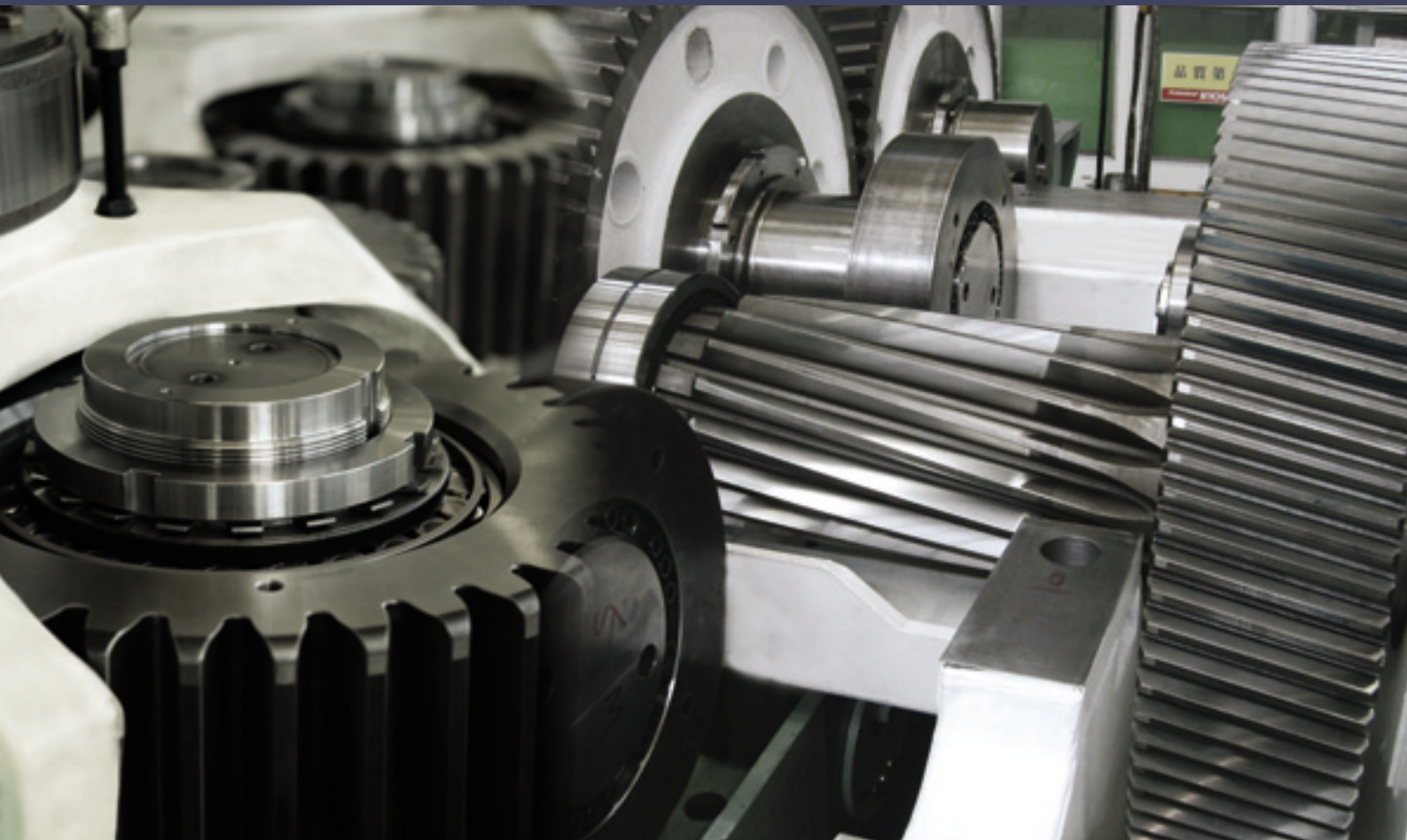

About HYOSUNG



Hyosung Power & Industrial Systems PG is a division under Hyosung which consists of seven performance groups (PGs). In addition to establishing itself as a world-class manufacturer of electrical equipments, green technology and industrial machineries, Hyosung is also the largest producer of tire cords and spandex in the global market and the second largest supplier of ATMs in the USA.

01 Our Business

Brief introduction of Hyosung Power & Industrial Systems

Hyosung Power & Industrial Systems Performance Group

Hyosung Power & Industrial Systems Performance Group, a comprehensive energy solution provider, boasts world-leading technology in the global power industry and has secured a competitive capability on par with that of top competitors in transformers, switchgears, motors, decelerators, industrial pumps, and wind energy business.

With globalization as one of our top priorities, we have achieved outstanding increase in sales over the past few years thanks to the enhancement in Hyosung's quality, technology, and brand recognition among overseas clients, which include North America, Europe, the Middle East, and Asia. We expect such robust performance, marked by an increasing number of orders from the overseas market, to continue in the future.

At the heart of our capability to grow as a comprehensive energy solution provider is our global organization structure. Hyosung Power & Industrial Systems Performance Group is divided into four business areas or performance units, depending on the types of flagship products: Power Systems Performance Unit, Industrial Machinery Performance Unit, Hyosung GoodSprings Performance Unit, and the Wind Energy Business Division.



Industrial Machinery Performance Unit

The Industrial Machinery Performance Unit Plays an important role in the infrastructure industry around the globe and is specialized in manufacturing all types of motors, gear reducers, generators, green energy, and industrial machines.

With the ability to produce motors with up to 20,000kW, we possess an automated production line capable of manufacturing more than 40,000 motors every month.

Our accumulated technologies and various experiences have made it possible to develop turnkey-based engineering projects including industrial plant, ropeways, energy solutions, and alternative refueling systems.

In addition, we anticipate that our efforts in innovation among rotary machinery will make significant contributions towards creating energy profitability as well as greater efficiency. With the goal to serve as a world-leading provider of industrial machinery and plant engineering, we will continue to focus on innovative energy conservation technology, enhanced reliability of new products, and development of new technologies.



GEAR REDUCER

CONTENTS

02 Our Business 03 Sustainability / R&D 04 HYOSUNG Gear Reducer 06 Type & Construction 08 Service Factors & Load Characteristics
09 Service Factors Table 10 General Information 11 Selection Guidelines 12 Rating Table & Dimensions-Parallel Shaft Type
(12 Single Reduction 14 Double Reduction 16 Triple Reduction 18 Quadruple Reduction) 20 Rating Table & Dimensions-Right Angle Type
(20 Double Reduction 22 Triple Reduction 24 Quadruple Reduction) 26 Low Speed Overhung Loads 27 Hollow Shaft Design

02 Sustainability

Our sustainability principles are the backbone of the way we design and manufacture products

Quality Assurance

Hyosung strives for excellence. We believe excellence can only be achieved through absolute quality and value for customers. In order to create quality products, we believe that all of the actions of every single employee must be focused in the highest level of quality. In order to achieve such levels, we have implemented a quality assurance policy and programs that make our philosophy into a reality. Our Quality Assurance Policy was founded based on the management policy of the president and meets the demands of ISO 9001. As a globally active company, we are committed to comprehensive and quality management through three quality strategies: quality management system, customer-focused management system, and concentration on core competencies.

The comprehensive quality management system ensures that we completely comply with all compliances and applicable legislation, codes, and standards in addition to implementing efficient operation of our management resources to eliminate unnecessary waste. Our customer-focused management system clarifies and simplifies our first priority which is customer satisfaction. All of our work is aimed to exceed customer needs and provide exceptional value through quality standards, flexibility, and innovation. Finally, we concentrate on our core competencies for strict quality control and continual improvement which provides quality products and cost-saving to our clients via advancement in technical capacity and technological innovation.

We implement our policy via a Quality Management Team manages research laboratories, including the Measurement Standard Laboratory, the Chemical Analysis Laboratory and the Material Analysis Laboratory to maintain a strict control over quality.



Environment Protection Policy

Hyosung understands the impact of Hyosung's activities in the environment and works to protect the environment from pollution, manages the environmental impacts of Hyosung's products and technologies, and prevents future pollution and harmful effects in the environment by investing in environmentally-friendly products and solutions. Based on this eco-philosophy of shared responsibility, Hyosung has implemented a comprehensive environmental protection program that aims to minimize our impact on the environment and conserve resources. Our environmental policy fulfils all requirements of the ISO 14001.

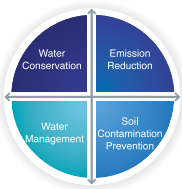

03 R&D

Inspiring innovation, creation and expertise

Hyosung R&D Center identifies innovation, creation, and expertise as core value, and concentrates on world class R&D activities in the 21st century with a philosophy aspiring after customer satisfaction, quality priority, and performance orientation. Hyosung pursues to be the world's best company in the field of heavy electrical machinery, industrial & electrical electronics engineering, and energy system. Ever since establishment in 1978, R&D Center had led the development of domestic technology. Along with the Anyang and Changwon labs, the group has endeavored to produce core technology and world-class products in the areas of heavy electrical machinery, energy system, electrical electronics engineering, and industrial automation system.

Research Areas

Hyosung R&D Center engages in the activities in the field of energy system, solution & service, applied electrical and electronic technology, basic core technology, technology of improved reliability, core components, and new materials.

Energy System

- Renewable energy (wind system, wind turbine, wind PCS, solar system, PV PCS, fuel cell, co-generation)
- Electric Vehicle (EV charger, EV motor)

Solution & Service

- Power facility diagnosis algorithm and system
- Power facility lifecycle evaluation system
- Service solution for remote diagnosis for prevention

Applied Electrical & Electronic Technology

- Power conversion system
- Flexible AC transmission system and high voltage direct current
- Power quality solution

Basic Core Technology

- Fortified technology in structural dynamics, electromagnetics, heat transfer analysis, etc.
- Skills for system simulation, analysis and evaluation
- Business support technology

Technology with Improved Reliability

- Test data analysis and testing facility
- Analysis of lifecycle and cause of error
- Reliability assessment (environment-friendliness, durability, long-term degradation, and more)

Core Components and New Materials

- Organic and inorganic insulation materials
- Silicon forming technology
- Intelligent sensor (facility diagnosis, CT, PT, VT, LA, and more)

HYOSUNG Gear Reducer

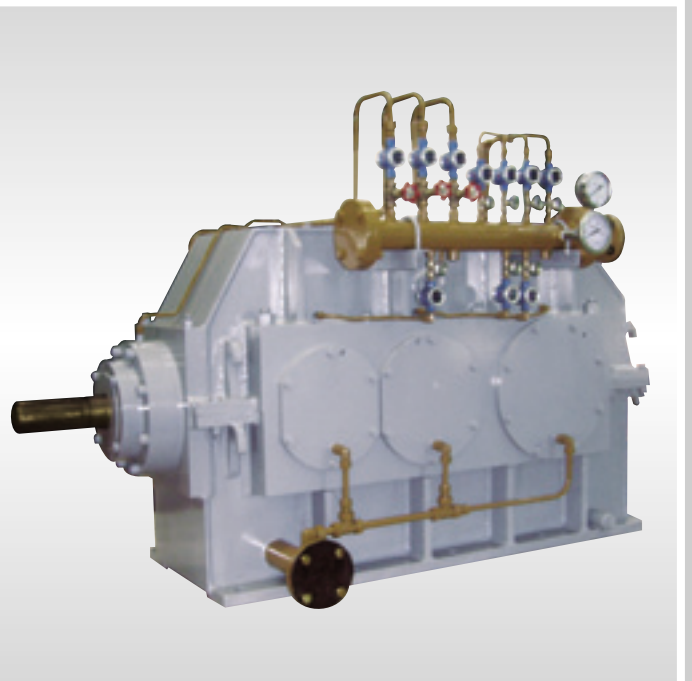

Since 1962, HYOSUNG CORPORATION has been manufacturing products of the highest quality and integrity. With superior design technology and highly advanced and automated manufacturing facilities, HYOSUNG products are built to last.

A superior Quality Management System is standard at HYOSUNG, and our team of professionally skilled workman continuously monitor the manufacturing process to insure an efficient, reliable and top quality product. At HYOSUNG we offer a wide selection of gear reducers that can handle any industrial application.

We offer 11 sizes with ratios up to 500:1 and torque ratings up to 40,000Kg-m output. All gear reducers come with a wide array of standard accessories, configurations and engineered options.

Our ISO 9001 Certificate rating guarantees a product of excellence, beginning with the original design and manufacturing, and continuing through to delivery, and our commitment to customer service.

With 35 locations throughout the world, HYOSUNG caters to an international market with HYOSUNG products and services available 24 hours a day with Customer Satisfaction Our Number One Goal.

Parallel Shaft & Right Angle Reducers

- 11 Sizes
- Ratios Up To 500:1
- Torque Ratings Up to 40,000Kg-m Output

Gears and Pinions

Helical gear teeth are cut on high quality, alloy steel material, then carburized, hardened, and precision ground. The resulting gears and pinions provide high durability ratings with decreased stress and dynamic loads, which provides longer life. Meets AGMA Level 12 specifications.

Shafts

Output shafts are made of heat treated, Maximum strength carbon steel, through hardened prior to turning and grinding. Close tolerance bearing shoulders facilitate the mounting of bearings. Highly polished surfaces are provided for oil seals to assure their long life. Large diameters are specified throughout for maximum strength and overhung load capacity.

Bearings

Husky roller bearings provide maximum longevity. Output shafts have high capacity roller bearings for heavy overhung and thrust loads.

Seals

Dual lip type oil seals are standard. Grease purged and labyrinth seals are available options.

Housings

Rugged fabricated steel housings constructed to exacting specifications are standard. Special configurations and castings also available.

Lubrication

Continuous splash lubrication including troughs and feeds and drains to bearings is used on most ratios and speeds. Forced lubrication utilizing oil pumps, filters, heat exchangers, sight gauges and alarm systems is available. Lubrication systems are designed for floor mounting. Other mounting positions are permissible with the concurrence of our Engineering Department.

Efficiency

Based on 100% load and 100% speed the approximate efficiency of parallel shaft units is 98% for double reduction, 97.5% for triple reduction, and 96.5% for quadruple reduction. For right angle units approximate efficiencies are 97.5% for double reduction, 97% for triple reduction, and 96% for quadruple reduction. Actual operating efficiencies may deviate slightly.

Inspection Port

All reducers are supplied with an oversize inspection port.

Oil Level Accuracy

Sight gauges are standard on all models and Dip Stick arrangements are available.



Type & Construction

Parallel Shaft Type : SH

Single Reduction

SHA

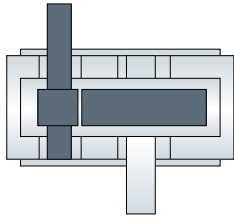

Double Reduction

SHB

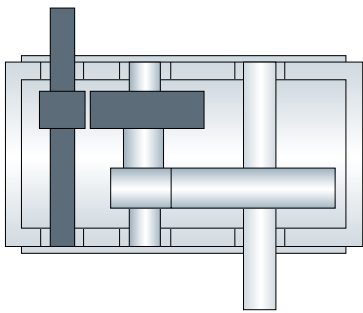

Triple Reduction

SHC

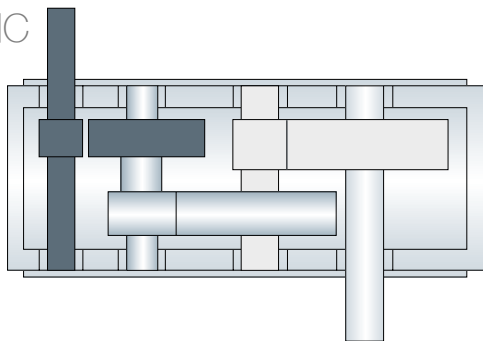

Quadruple Reduction

SHD

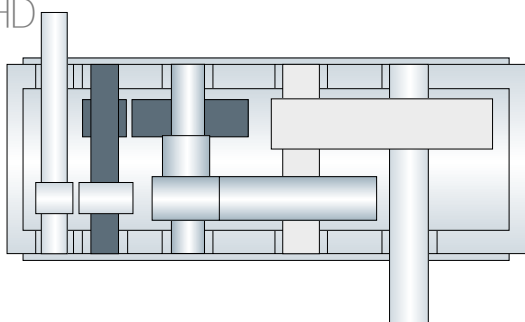

Right Angle Type : SK

Double Reduction

SKB

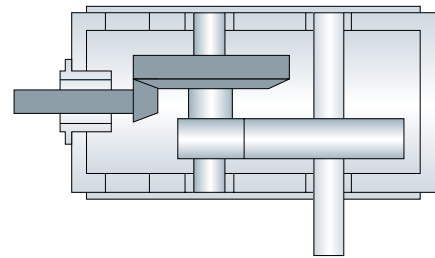

Triple Reduction

SKC

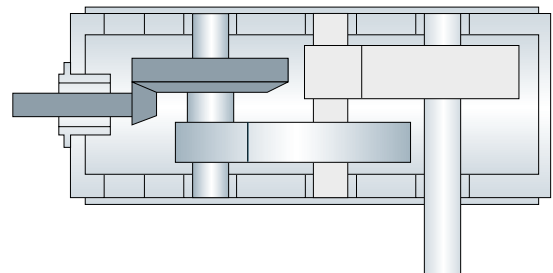

Quadruple Reduction

SKD

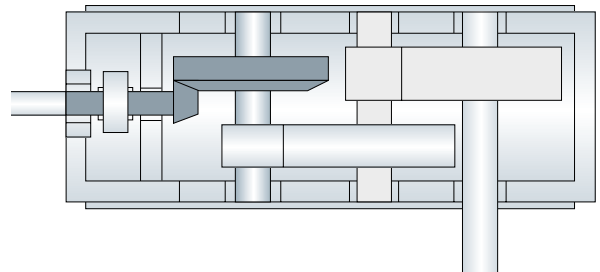

Example of Unit Identification

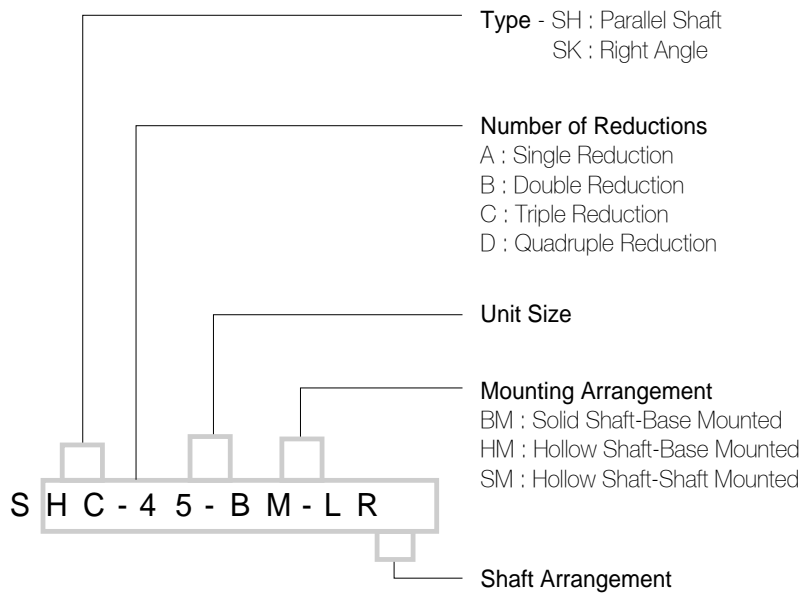

Reducers can be supplied with

- Solid Output Shaft
- Hollow Shaft with Shrink Disk
- Hollow Shaft with Keyway

Shaft Arrangement

Parallel Shaft Type (Horizontal)

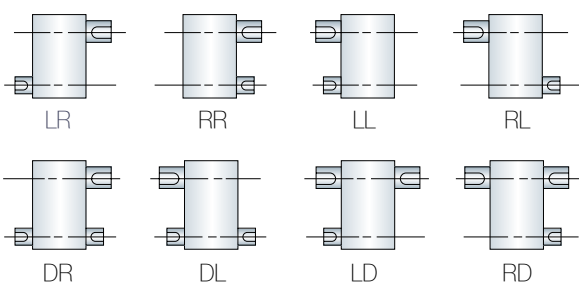

Right Angle Type

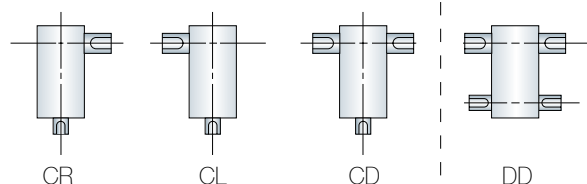

*VIEW FROM TOP.

Modifications' Electric Motor

Optional equipments and modifications are available with HYOSUNG reducers to meet the exact specifications of your installation.

Contact our Sales Representative with your requirements for :

- Special Shaft Extensions
- Lubrication Systems
- Auxiliary Cooling
- Sump Heaters
- Bedplates
- Coupling and Coupling Guards
- Backstops, Clutches and Brakes
- Outboard Pinions and Bearings

Service Factors & Load Characteristics

Service factors and load characteristics in the tables on page 9 and in the conversion chart below classify the character of the load in various applications so that a proper speed reducer can be selected for a given service. The actual load, and not the rating of the motor or prime mover, is to be used in determining the unit selection. Applications with high torque motors, and motors for intermittent operations, and applications where extreme repetitive shock occurs, or where high energy loads must be absorbed, as when stalling, require special consideration and are not covered by service factors given in the tables. Applications involving unusual or severe loading or requiring a high degree of dependability should be carefully reviewed with our Engineering Department.

Service factors represent the normal relationship between gear design power rating and the continuous power requirements. Commonly recognized classifications of service factors are uniform, moderate shock, and heavy shock.

When drives are equipped with brakes on the input, and the torque rating of the brake exceeds the rating of the motor, the rating of the brake dictates the selection of the gear unit.

For infrequent starting (less than 5 starts per hour) the maximum momentary or starting load should not exceed 275% of rated load (175% overload). For frequent starting (More than 5 starts per hour), the actual maximum momentary or starting load shall not exceed 200% of rated load (100% overload). Rated load is defined as the unit rating with a service factor of 1.0.

Responsibility : The manufacturer's published warranty applies to the enclosed drives described in this publication provided the following conditions are met.

The unit is protected from the elements, as prescribed by the manufacturer, in either inside or outside storage, between the interval of its receipt by the buyer and actual installation.

The unit is properly installed and lubricated in accordance with the manufacturer's instructions.

The system of connected rotating parts is compatible, free from critical speed, torsional or other type vibration, which the specified operating speed range, no matter how induced. Responsibility for system analysis, in compliance with these requirements, rests with purchaser of the gear unit.

The transmitted load, imposed torsional, thrust and overhung loads are within the capacity limits for which the unit was sold, or as specified in the purchase contract.

Exceptions to any of the foregoing provisions are a matter of specific contractual agreements.

Service Factor Conversions

Multi-cylinder engine driven applications and intermittent operations up to 3 hours per day require and upgraded service factor. Locate the service factor for your application in the electric or hydraulic motor drives table and convert by substituting the factor from this conversion table.

Prime Mover	Duration of Service	Load Class		
		U	M	H
Electric or Hydraulic Motor	Up to 3 hrs/day	0.80	1.00	1.50
	3 to 10 hrs/day	1.00	1.25	1.75
	Over 10 hrs/day	1.25	1.50	2.00
Multi-Cylinder Engine	Up to 3 hrs/day	1.00	1.25	1.75
	3 to 10 hrs/day	1.25	1.50	2.00
	Over 10 hrs/day	1.5	1.75	2.25

* Footnotes for service factors table

* Service factors are minimum values recommended. Refer to conversion table on page 8.

△ Contact HYOSUNG sales Representative or Engineering Department.

Note 1 : Service factors for paper mill application are applied to name plate rating of electric drive motor at the motor rated base speed.

Note 2 : A service factor of 1.00 may be applied at base speed of a super calender operating over speed range of part range, constant horsepower, part range, constant torque where the constant horsepower speed range is greater than 1.5 to 1.0 A service factor of 1.25 is applicable to super calendar operating over the entire speed range at constant torque or where the constant horsepower speed range is less than 1.5 to 1.0.

Service Factors Table

Application	Service		Application	Service		Application	Service	
	10 Hrs/Day	24 Hrs/Day		10 Hrs/Day	24 Hrs/Day		10 Hrs/Day	24 Hrs/Day
Agitators(Mixers)	1.00	1.25	Lumber Industry			Extruder	1.50	1.50
pure Liquids	1.25	1.50	Barkers-Spindle Feed	1.25	1.50	Fourdrinier Rolls	1.25	1.25
liquids and Solid	1.25	1.50	- Main Drive	1.75	1.75	Jordan	1.50	1.50
Liquids-Variable Density			Conveyors-Burner	1.25	1.50	Kiln Drive	1.50	1.50
Blowers			- Main of Heavy Duty	1.50	1.50	Mt. Hope Rolls	1.25	1.25
Centrifugal	1.00	1.25	- Main Log	1.75	2.00	Paper Rolls	1.25	1.25
Lobe	1.25	1.50	- Re-Saw			Platter	1.50	1.50
Vane	1.00	1.25	Merry-Go-Round	1.25	1.50	Presses-Felt & Suction	1.25	1.25
Brewing and Distilling			- Slab	1.75	2.00	Pulper	2.00	2.00
Bottling machinery	1.00	1.25	-Transfer	1.25	1.50	Pumps-Vaccum	1.50	1.50
Brew Kettles, Cont. Duty	1.00	1.25	Chains-Floor	1.50	1.50	Reel(Surface Type)	1.25	1.25
Cookers-Cont. Duty	1.00	1.25	- Green	1.50	1.75	Screens-Chip & Rotary	1.50	1.50
Mash Tubs-Cont. Duty	1.00	1.25	Cut-Off Saws	1.50	1.75	- Vibrating	2.00	2.00
Scale Hopper, Freq. Starts	1.25	1.50	Debarking Drums	1.75	2.00	Size Press	1.25	1.25
Can Filling Machines	1.00	1.25	Feeds-Edger	1.25	1.50	Super Calender-(See Note 2)	1.25	1.25
Car Dumpers	1.75	2.00	- Gang	1.75	1.75	Thickener(AC Motor)	1.50	1.50
Car Pullers	1.25	1.50	- Trimmer	1.25	1.50	- (DC Motor)	1.25	1.25
Clarifiers	1.00	1.25	Log Deck	1.75	1.75	Washer(AC Motor)	1.50	1.50
Classifiers	1.25	1.50	Log Hauls-Incline-Well Type	1.75	1.75	- (DC Motor)	1.25	1.25
Clay Working machinery			Log Turning Devices	1.75	1.75	Wind & Unwind Stand	1.00	1.25
Brick Press	1.75	2.00	Planer Feed	1.25	1.50	Winders(Surface Type)	1.25	1.25
Briquette Machine	1.75	2.00	Planer Tilting Hoists	1.50	1.50			
Pug Mill	1.25	1.50	Rolls-Live-Off Brg-Roll-Casses	1.75	1.75	Plastic Industry		
Compactors	2.00	2.00	Sorting Table	1.25	1.50	Blow Molders	1.50	1.50
Compressors			Tripple Hoist	1.25	1.50	Coating	1.25	1.25
Centrifugal	1.00	1.25	Transfers-Chain or Craneway	1.50	1.75	Film	1.25	1.25
Lobe	1.25	1.50	Tray Drives	1.25	1.50	Pipe	1.25	1.25
Reciprocating Multi Cyl.	1.50	1.75	Veneer Lathe Drives	1.25	1.50	Pre-plasticizers	1.50	1.50
Reciprocating Single-Cyl.	1.75	2.00	Metal Mills			Rods	1.25	1.25
Conveyors			Draw Bench Carriage and			Sheet	1.25	1.25
Uniformly Loaded or fed	1.00	1.25	Main Drive	1.25	1.50	Tubing	1.25	1.50
Not uniformly fed	1.25	1.50	Run Out Tables			Pumps		
Reciprocating or Shaker	1.75	2.00	Non-Reversing			Centrifugal	1.00	1.25
Cranes	△	△	Group Drives	1.50	1.50	Proportioning	1.25	1.50
Crusher			Individual Drives	2.00	2.00	Reciprocating		
Stone or Ore	1.75	2.00	Reversing	2.00	2.00	Single or Double Acting	1.25	1.50
Dredges			Slab Pushers	1.50	1.50	Rotary	1.00	1.25
Cable Reels	1.25	1.50	Shears	2.00	2.00			
Conveyors	1.25	1.50	Wire Drawing	1.25	1.50	Rubber Industry	△	△
Cutter Head Drives	2.00	2.00	Wire Winding Machine	1.50	1.50			
Pumps	2.00	2.00				Sand Muller	1.25	1.50
Screen Drives	1.75	2.00	Metals Strip Processing Machinery			Sewage Disposal Equipment		
Stackers	1.25	1.50	Bridles	1.25	1.50	Bar Screens	1.25	1.25
Winches	1.25	1.50	Coilers & Unicoilers	1.00	1.25	Chemical Feeders	1.25	1.25
Elevators			Edge Trimmers	1.25	1.50	Dewatering Screens	1.50	1.50
Bucket	1.25	1.50	Flatteners	1.25	1.50	Scum Breakers	1.50	1.50
Centrifugal Discharge	1.00	1.25	Loopers(Accuumulators)	1.00	1.25	Slow or Rapid Mixers	1.50	1.50
Escalators	1.00	1.25	Pinch Rolls	1.25	1.50	Sludge Collectors	1.25	1.25
Freight	1.25	1.50	Scrap Choppers	1.25	1.50	Thickeners	1.50	1.50
Gravity Discharge	1.00	1.25	Shears	2.00	2.00	Vacuum Filters	1.50	1.50
Extruders			Slitters	1.25	1.50	Screens		
General	1.50	1.50	Mills, Rotary Type			Air Washing	1.00	1.25
Plastics-Var. Speed Dr.	1.50	1.50	Ball & Rod			Rotary-Stone or Gravel	1.25	1.50
Fixed Speed Drive	1.75	1.75	Spur Ring Gear	2.00	2.00	Traveling Water Intake	1.00	1.25
Rubber-Cont. Screw	1.75	1.75	Helical Ring Gear	1.50	1.50	Sugar Industry		
Intermittent Screw	1.75	1.75	Direct Connected	2.00	2.00	Beet Slicer	2.00	2.00
Fans			Cement Kilns	1.50	1.50	Cane Knives	1.50	1.50
Centrifugal	1.00	1.25	Dryers & Coolers	1.50	1.50	Crushers	1.50	1.50
Cooling Towers	2.00	2.00	Mixer, Concrete	1.25	1.50	Mills(low speed end)	1.75	1.75
Forced Draft	1.25	1.25	Paper Mills(See Note 1)			Textile Industry		
Induced Draft	1.50	1.50	Agitators(Mixer)	1.50	1.50	Batchers	1.25	1.50
Industrial & Mine	1.50	1.50	Agitator for Pure Liquors	1.25	1.25	Calenders	1.25	1.50
Feeders			Barking Drums	2.00	2.00	Cards	1.25	1.50
Apron or Belt	1.25	1.50	Barkers-Mechanical	2.00	2.00	Dry Cans	1.25	1.50
Disc	1.00	1.25	Beater	1.50	1.50	Dryers	1.25	1.50
Reciprocating	1.75	2.00	Breaker Stack	1.25	1.25	Dyeing machinery	1.25	1.50
Screw	1.25	1.50	Calender	1.25	1.25	Looms	1.25	1.50
Food industry			Chipper	2.00	2.00	Mangles	1.25	1.50
Cereal Cooker	1.00	1.25	Chip Feeder	1.50	1.50	Nappers	1.25	1.50
Dough Mixer	1.25	1.50	Coating Rolls	1.25	1.25	Pads	1.25	1.50
Meat Grinders	1.25	1.50	Conveyors-Chip, Bark, Chemical	1.25	1.25	Slashers	1.25	1.50
Slicers	1.25	1.50	-Log(including Slab)	2.00	2.00	Soapers	1.25	1.50
Generators & Exciters	1.00	1.25	Couch Rolls	1.25	1.25	Spinners	1.25	1.50
Hammer Mills	1.75	2.00	Cutter	2.00	2.00	Tenter Frames	1.25	1.50
Hoists	△	△	Cylinder Molds	1.25	1.25	Washers	1.25	1.50
Laundry tumblers	1.25	1.50	Dryers(Anti-Frcition, bearings)	1.25	1.25	Winders	1.25	1.50
Laundry Washers	1.50	2.00	Embosser	1.25	1.25			

*Foot Note : See Page8

General Information

Service Factors

Service factors serve to modify the mechanical power ratings. In practice the actual power rating to be transmitted is multiplied by the selected service factor to obtain what is called the equivalent power. This equivalent (mechanical) power is used to select the reducer from the rating tables. Service factors are not applied to the thermal power but only to the mechanical power.

Mechanical Ratings

The mechanical power rating listings on pages 12 through 25 are for continuous 8 to 10 hour service and allow 100% overload in starting and for momentary shock loads. All components are designed to permit fewer than 5 starts per hour peak loads of 275% of catalog ratings without stresses exceeding 75% of the material yield point.

Where the mechanical rating exceeds the thermal rating, the full mechanical rating may be applied, provided that adequate cooling provisions are made.

Thermal Ratings

Thermal ratings are listed in power rating on pages 12 through 25. The thermal power rating is the rating of how much power a unit will continuously transmit for 3 hours or more without undue temperature rise. It is applied only when the mechanical power is higher and no cooling provisions are made.

Thermal ratings need not be considered when the continuous operating period does not exceed three hours and the shutdown time equals or exceeds the operating time. When the running time exceeds the shutdown time, selection must be made on the basis of the thermal rating or cooling provisions must be made. Consult our Engineering Department for cooling system recommendations.

Overhung Loads

Overhung load ratings in kg for low speed shafts are listed on page 26. High speed shaft overhung load values are not listed.

When the shaft of the speed reducer carries an overhung load, find the allowable shaft pull for the selected unit from the following formula.

$$\text{pull} = \frac{F \times 1,948,000 \times \text{KW}}{D \times \text{RPM}}$$

Where, KW=actual power to be transmitted.

RPM=revolutions per minute of shaft.

D=Pitch diameter in mm of pinion, sprocket, or diameter of pulley or sheave on shaft.

F=factor having following values;

Sprocket = 1.0 / pinion = 1.25 / V Belt = 1.5 / Flat Belt = 2.5

The allowable overhung loads, as listed, are calculated to be applied at the center of the shaft extensions which are designed as dimensions "L1" and "L2" on the dimension pages. For overhung loads in excess of those listed, consult company for suitable recommendations.

Warranty

HYOSUNG warrants for one year that the speed reducers shown in this catalog will conform to applicable rated specification as indicated, provided the unit is properly installed, maintained and operated within the limit of speed, torque and load conditions for which it was sold.

The equipment is expressly not warranted against failure or unsatisfactory operation resulting from dynamic vibrations of any from imposed upon it by the drive system in which it is installed, no matter how induced, unless the specific conditions have been made known to HYOSUNG and explicitly accepted as a condition of the order.

Install and operate HYOSUNG products in conformance with applicable local and national safety codes and per installation manuals which are available upon request.

Refer to HYOSUNG quotation from full warranty statement.

Selection Guidelines

Power Method

1. Determine Service Factor
2. Calculate Equivalent KW
3. Determine Ratio
4. Determines Size of Unit
5. Verify Overhung Load Rating
6. Check Shaft and Mounting Dimensions.

Torque Method

1. Determine Service Factor
2. Calculate Equivalent Torque
3. Determine Ratio
4. Determine Size of Unit
5. Verify overhung Load Rating
6. Check Shaft and Mounting Dimensions.

Example 1

Require a parallel Shaft type reducer to transmit 75 KW at 1750 RPM input, for 10 hours per day operation, driving a centrifugal pump at 30 RPM. Motor is electric and pump load is uniform

1. Service factor from page 9 is 1.0.
2. Equivalent KW = $75 \text{ KW} \times 1.0 \text{ SF}$
= 75 KW
3. Ratio = $\frac{1750\text{RPM}}{30\text{RPM}} = 58.3 : 1$
4. Unit Selection-Start at the top of page 16 and read down the first column to 56:1 ratio, then read across unit the mechanical KW value is 89.
The column heading indicates unit size of SHC 26 for this application.
5. Solution-Size SHC 26, ratio 56:1 \pm 3% rated 89 KW at 1750 RPM input, Actual SF = 1.19

Example 2

Require a parallel Shaft type reducer to transmit 780 Kg-m of output torque at 72 RPM. Driver is a multi-cylinder gas engine driving a cement mixer up to 10 hrs. per day.

1. Service Factor from page 9 is 1.25. Converted service factor from table on page 8 is 1.50.
2. Calculate Equivalent Torque $780 \times 1.50 = 1,170 \text{ Kg-m}$
3. Determine Ratio = $\frac{1750\text{RPM input}}{72\text{RPM Mixer}} = 24.3$
4. Unit Selection-Start at the top of page 14 and read down the first column to 25:1, then read across until the output torque value is 1,215.
The column heading indicates a unit size of SHB22.
5. Solution-Size SHB22, ratio 25:1 \pm 3% rated 1,215 Kg-m output torque at 1750 RPM input, actual SF=1.56.



Single Reduction

Permissible Transmitting Power Ratings

UNIT : kW

Nominal Ratio	Speed		Gear Unit Size								
	Input rpm	Output rpm	12	16	18	22	26	32	38	45	50
Mechanical Power Ratings											
2	1800	900	214	456	690	1212	1812	-	-	-	-
	1200	600	142	300	474	804	1212	2646	3930	5922	-
	900	450	108	228	348	606	906	1992	2946	4440	-
2.24	1800	804	202	402	606	1098	1662	3024	-	-	-
	1200	536	132	264	402	732	1110	1920	3618	5418	-
	900	402	101	204	300	546	834	1512	2712	4062	-
2.5	1800	720	176	336	528	996	1512	2682	-	-	-
	1200	480	118	228	354	660	1003	1788	3150	4914	-
	900	360	88	168	264	498	756	1344	2364	3684	-
2.8	1800	643	151	288	456	858	1476	2520	-	-	-
	1200	429	101	192	300	570	984	1680	2898	4422	5604
	900	321	76	144	228	426	738	1260	2172	3318	4206
3.15	1800	571	126	240	402	732	1236	2280	3654	-	-
	1200	381	84	166	270	486	822	1518	2436	3930	4752
	900	286	62	120	204	366	618	1140	1824	2946	3564
3.55	1800	507	114	204	348	630	1093	1716	3150	4752	-
	1200	338	76	132	228	420	732	1140	2100	3168	4092
	900	254	56	102	174	312	546	858	1572	2376	3072
4	1800	450	108	174	300	552	930	1650	2682	4422	-
	1200	300	72	119	204	372	618	1098	1788	2946	3684
	900	225	53	88	150	276	468	828	1344	2208	2760
4.5	1800	400	88	156	264	438	792	1338	2394	3462	3389
	1200	267	58	104	174	294	528	888	1596	2310	3054
	900	200	44	78	132	222	396	666	1188	1734	2292
5	1800	360	70	132	228	390	678	1198	1966	3024	3840
	1200	240	46	88	150	258	456	793	1308	2016	2562
	900	180	34	66	114	192	342	540	984	1512	1920
5.6	1800	321	60	108	204	330	594	942	1728	2706	3276
	1200	214	40	72	132	216	396	630	1080	1806	2184
	900	161	30	53	101	162	294	474	864	1356	1638
6.3	1800	286	49	89	174	282	504	804	1410	2052	2862
	1200	190	32	60	118	186	336	534	942	1368	1908
	900	143	24	44	89	138	252	402	708	1026	1428

Thermal Ratings

UNIT : kW

Nominal Ratio	Speed		Unit Size								
	Input rpm		12	16	18	22	26	32	38	45	50
Without Auxiliary Cooling											
2 - 3.15	1800		56	84	111	170	216	328	393	-	-
	1200		53	80	106	162	206	312	374	581	711
	900		51	76	101	155	197	298	357	555	679
3.55 - 6.3	1800		52	77	103	157	200	303	363	564	691
	1200		49	73	97	148	188	285	342	529	649
	900		47	70	93	142	180	273	328	508	622
With Fan Cooling											
2 - 3.15	1800		87	130	173	264	335	508	608	946	1157
	1200		81	120	159	244	309	415	498	774	946
	900		75	111	147	225	286	384	461	716	875
3.55 - 6.3	1800		81	119	160	245	310	416	500	776	94
	1200		74	110	145	222	283	379	455	707	864
	900		68	102	135	207	223	352	423	655	802

Permissible Torque Ratings / WR2

	Nominal Ratio	Unit Size								
		12.5	16	18	22	26	32	38	45	50
Permissible Torque Ratings (UNIT : kgm)	2	230	486	742	1292	1932	4247	6281	9466	-
	2.24	241	487	716	1304	1991	3610	6476	9699	-
	2.5	233	448	704	1327	2015	3582	6300	9818	-
	2.8	226	609	681	1272	2203	3761	6483	9903	12554
	3.15	210	403	685	1229	2075	3828	6125	9892	11967
	3.55	213	386	658	1181	2066	3247	5949	8991	11625
	4	225	374	640	1177	1996	3531	5731	9415	11769
	4.5	213	374	633	1065	1900	3195	5699	8318	10995
	5	179	352	608	1023	1823	2878	5245	8059	10233
	5.6	179	315	602	967	1755	2830	5158	8095	9778
	6.3	161	298	596	927	1692	2700	4755	6890	9590
Rotational Inertia WR ² (UNIT : kgm ²)	2	0.0231	0.0768	0.148	0.3759	0.8529	2.1640	5.7827	12.4992	21.5027
	2.24	0.0217	0.0652	0.1328	0.3372	0.7538	1.9268	5.1773	11.0480	18.0741
	2.5	0.0196	0.0584	0.122	0.3049	0.7209	1.7272	4.4061	9.8197	16.1534
	2.8	0.0168	0.0562	0.1103	0.2616	0.6065	1.5438	3.9432	8.6818	13.6000
	3.15	0.0125	0.0445	0.0911	0.2351	0.5498	1.3728	3.4323	7.6254	12.4838
	3.55	0.0123	0.0373	0.0844	0.2050	0.4988	1.1230	3.1388	6.2881	11.1589
	4	0.0107	0.0345	0.0700	0.1669	0.3965	1.0242	2.6370	5.8862	10.4790
	4.5	0.0090	0.0321	0.0620	0.1422	0.3512	0.8611	2.2549	4.6034	8.8108
	5	0.0074	0.0243	0.0512	0.1322	0.2920	0.7090	1.8253	3.9265	7.0100
	5.6	0.0067	0.0215	0.0471	0.1107	0.2672	0.6242	1.5938	3.5242	5.9883
	6.3	0.0056	0.0179	0.0397	0.0959	0.2156	0.5369	1.3936	2.7650	4.9715

Parallel Shaft (SHA)

UNIT : mm

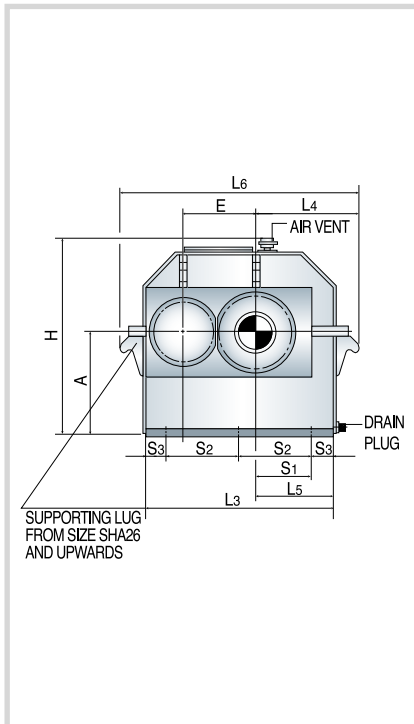

Unit Size	High Speed Shaft								
	Ratio : 2 - 2.8			Ratio : 3.15 - 4.5			Ratio : 5 - 6.3		
	D ₁	L ₁	Key	D ₁	L ₁	Key	D ₁	L ₁	Key
12	45	70	14 x 9	35	60	10 x 8	30	50	8 x 7
16	55	90	16 x 10	45	70	14 x 9	35	60	10 x 8
18	60	105	18 x 11	55	90	16 x 10	45	70	14 x 9
22	75	120	20 x 12	65	105	18 x 11	50	80	14 x 9
26	85	140	22 x 14	75	120	20 x 12	60	105	18 x 11
32	105	180	28 x 16	95	160	25 x 14	75	120	20 x 12
38	125	210	32 x 18	110	180	28 x 16	90	160	25 x 14
45	145	240	36 x 20	125	210	32 x 18	100	180	28 x 16
50	155	240	40 x 22	135	210	36 x 20	115	200	32 x 18

UNIT : mm

Unit Size	Dimensions										
	E	K ₁	K ₂	L ₃	L ₄	L ₅	L ₆	A	H	W	C
12	125	120	110	370	220	140	530	160	330	235	15
16	160	135	130	450	250	170	610	200	405	275	15
18	185	155	145	510	275	195	670	250	490	330	20
22	220	180	170	600	305	225	760	315	595	370	20
26	265	200	190	690	340	260	850	355	670	410	28
32	320	240	220	840	400	320	1000	400	780	480	28
38	385	270	250	970	440	360	1130	500	950	530	28
45	450	310	290	1150	540	440	1350	560	1070	620	35
50	500	335	320	1280	590	490	1480	630	1190	670	35

UNIT : mm

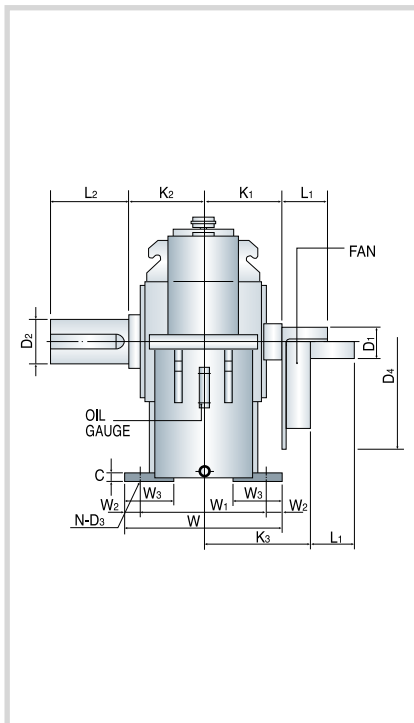

Unit Size	Low Speed Shaft				Hollow Shaft
	WT(kg)	Ratio : 2 - 2.8			
		D ₂	L ₂	Key	
12	95	55	90	16 x 10	Consult HYOSUNG Engineering Department
16	170	70	120	20 x 12	
18	280	85	140	22 x 14	
22	395	100	180	28 x 16	
26	625	120	210	32 x 18	
32	1020	140	240	36 x 20	
38	1490	155	240	40 x 22	
45	2260	190	310	45 x 25	
50	3100	210	350	50 x 28	

UNIT : mm

Unit Size	Dimensions								Fan Cooling	Oil Cap.	
	S ₁	S ₂	S ₃	W ₁	W ₂	W ₃	D ₃	N	D ₄	K ₃	Liter
12	95	140	45	195	20	80	14	6	265	200	3.2
16	125	180	45	230	23	90	18	6	310	225	5.5
18	140	200	55	270	30	110	22	6	335	245	11
22	175	250	50	310	30	120	22	6	480	270	21
26	195	280	65	350	30	130	26	6	480	290	27
32	260	240	60	420	30	150	26	8	540	330	46
38	280	270	80	470	30	155	26	8	540	360	73
45	365	250	75	550	35	180	33	10	635	400	100
50	420	285	70	600	35	190	33	10	735	425	150

*Shaft Tolerance d ≤ 80 = m6
d > 80 = n6

Parallel Shaft (SHB)

UNIT : mm

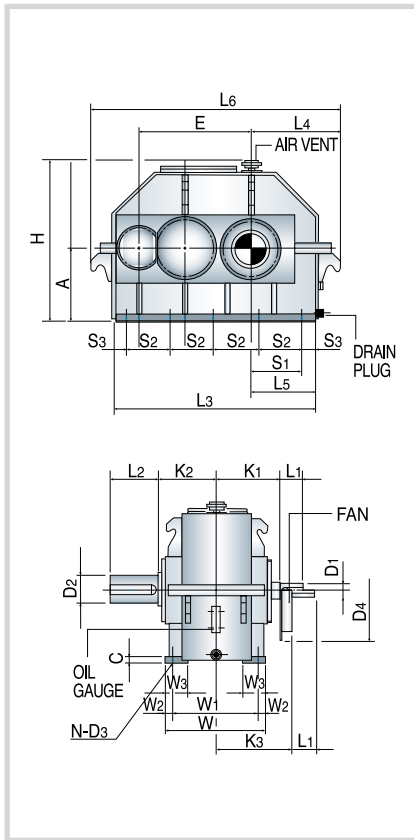

Unit Size	High Speed Shaft								
	Ratio : 7.1 - 11.2			Ratio : 12.5 - 22.4			Ratio : 25 - 28		
	D ₁	L ₁	Key	D ₁	L ₁	Key	D ₁	L ₁	Key
18	45	70	14 x 9	35	60	10 x 8	30	50	8 x 7
22	55	90	16 x 10	45	70	14 x 9	35	60	10 x 8
26	65	105	18 x 11	50	80	14 x 9	42	70	12 x 8
32	75	120	20 x 12	60	105	18 x 11	50	80	14 x 9
38	90	160	25 x 14	75	120	20 x 12	60	100	18 x 11
45	100	180	28 x 16	90	160	25 x 14	70	120	20 x 12
50	120	210	32 x 18	100	180	28 x 16	80	140	22 x 14
56	130	210	32 x 18	110	180	28 x 16	90	160	25 x 14
61	150	240	36 x 20	120	210	32 x 18	100	180	28 x 16
66	150	240	36 x 20	120	210	32 x 18	100	180	28 x 16
71	170	270	40 x 22	140	240	36 x 20	110	180	28 x 16

UNIT : mm

Unit Size	Dimensions										
	E	K ₁	K ₂	L ₃	L ₄	L ₅	L ₆	A	H	W	C
18	310	190	180	610	270	190	770	200	452	292	20
22	380	220	200	730	310	230	890	250	561	332	20
26	450	260	240	840	340	260	1000	280	640	408	28
32	540	305	280	1000	380	300	1160	355	765	490	28
38	650	330	310	1170	450	350	1370	400	860	530	28
45	770	390	370	1390	510	410	1590	500	1019	650	35
50	885	420	400	1570	575	455	1810	560	1119	710	35
56	940	470	440	1680	620	500	1920	630	1239	780	40
61	1060	525	500	1870	670	550	2110	710	1379	900	45
66	1110	530	510	1990	710	590	2230	750	1469	920	45
71	1205	580	560	2140	775	635	2480	800	1549	1010	50

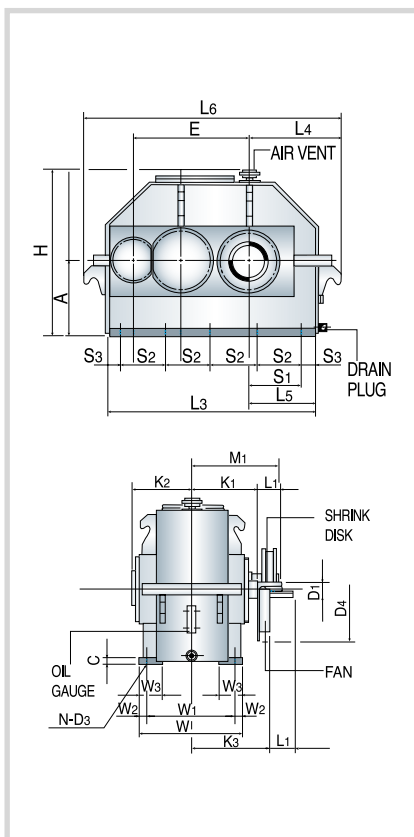

Unit Size	Low Speed Shaft					
	Solid Shaft			Hollow Shaft		
	WT(kg)	D ₂	L ₂	Key	WT(kg)	
18	285	80	140	22 x 14	262	
22	470	100	180	28 x 16	432	
26	745	120	210	32 x 18	685	
32	1300	140	240	36 x 20	1196	
38	1905	170	270	40 x 22	1753	
45	3150	200	350	45 x 25	2898	
50	4160	220	350	50 x 28	3827	
56	5170	240	400	56 x 32	4756	
61	7100	270	450	63 x 32	6531	
66	7740	290	450	63 x 32	1721	
71	9710	310	500	70 x 36	8933	

Refer to page 26 and 27 for shaft dimensions

UNIT : mm

Unit Size	Dimensions							Fan Cooling		Oil Cap.	
	S ₁	S ₂	S ₃	W ₁	W ₂	W ₃	D ₃	N	D ₄	K ₃	Liter
18	155	135	35	260	16	56	14	10	350	280	13
22	195	165	35	290	21	66	18	10	430	310	21
26	220	190	40	355	26.5	89	22	10	430	350	32
32	250	225	50	430	30	95	26	10	480	395	65
38	305	270	45	465	32.5	100	26	10	480	420	85
45	365	325	45	570	40	120	33	10	540	480	170
50	390	360	65	640	35	125	33	10	575	510	240
56	440	390	60	690	45	135	39	10	635	560	330
61	475	430	75	800	50	155	45	10	635	615	470
66	515	460	75	820	50	160	45	10	735	620	550
71	545	490	90	910	50	168	45	10	735	670	680

*Shaft Tolerance d ≤ 80 = m6
d > 80 = n6

Parallel Shaft (SHC)

UNIT : mm

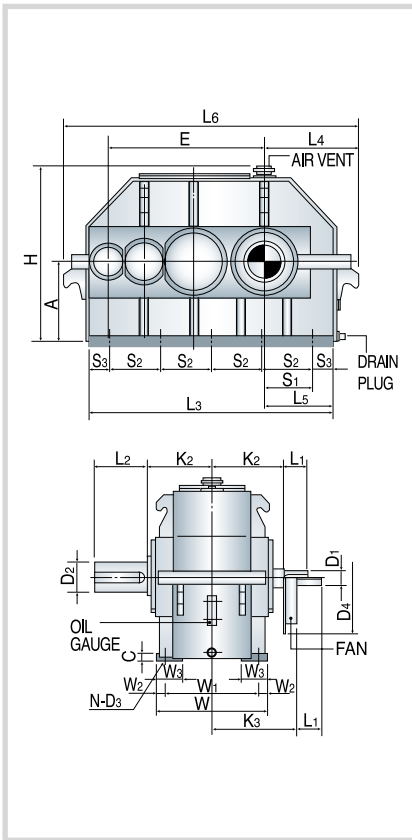

Unit Size	High Speed Shaft					
	Ratio : 28 - 63			Ratio : 71 - 112		
	D ₁	L ₁	Key	D ₁	L ₁	Key
18	25	40	8 x 7	20	35	6 x 6
22	30	50	8 x 7	25	40	8 x 7
26	38	60	10 x 8	28	50	8 x 7
32	45	70	14 x 9	35	60	10 x 8
38	55	90	16 x 10	42	70	12 x 8
45	65	105	18 x 11	50	80	14 x 9
50	75	120	20 x 12	60	105	18 x 11
56	80	140	22 x 14	65	105	18 x 11
61	90	160	25 x 14	75	120	20 x 12
66	100	180	28 x 16	80	140	22 x 14
71	110	180	28 x 16	90	160	25 x 14

UNIT : mm

Unit Size	Dimensions										
	E	K ₁	K ₂	L ₃	L ₄	L ₅	L ₆	A	H	W	C
18	400	175	170	670	265	185	830	200	445	270	20
22	505	195	190	820	295	215	980	250	525	310	20
26	575	220	215	940	335	255	1100	280	640	360	28
32	700	260	250	1130	395	295	1330	355	740	430	28
38	835	300	285	1330	445	345	1530	400	870	490	28
45	990	360	350	1570	530	410	1810	500	1030	600	35
50	1150	400	390	1830	620	500	2070	560	1125	680	35
56	1205	400	390	1910	645	525	2150	630	1230	680	40
61	1380	470	460	2170	715	575	2450	710	1370	820	45
66	1430	470	460	2260	755	615	2540	750	1470	820	45
71	1590	510	500	2500	810	670	2780	800	1570	900	50

UNIT : mm

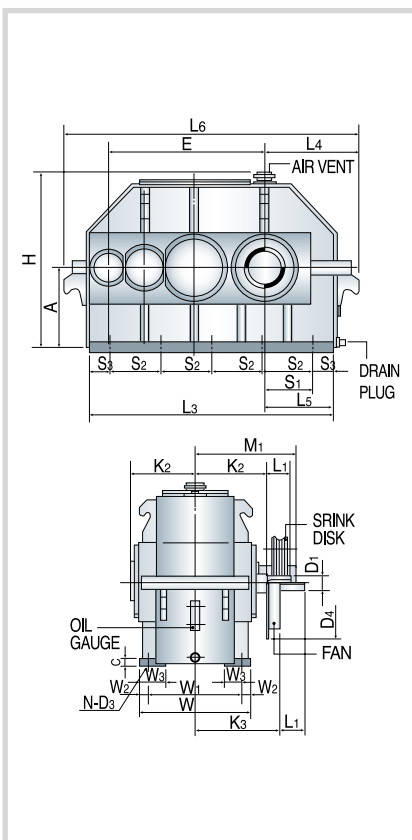

Unit Size	Low Speed Shaft					
	Solid Shaft			Hollow Shaft		
	WT(kg)	D ₂	L ₂	Key	WT(kg)	
18	295	80	140	22 x 14	271	
22	455	100	180	28 x 16	419	
26	730	120	210	32 x 18	672	
32	1150	140	240	36 x 20	1058	
38	1750	170	270	40 x 22	1610	
45	3150	200	350	45 x 25	2899	
50	4120	220	350	50 x 28	3790	
56	4925	240	400	56 x 32	4531	
61	7395	260	450	56 x 32	6803	
66	8345	280	450	63 x 32	7677	
71	10650	300	500	70 x 36	9798	

Refer to page 26 and 27
for shaft dimensions

UNIT : mm

Unit Size	Dimensions							Fan Cooling		Oil Cap.	
	S ₁	S ₂	S ₃	W ₁	W ₂	W ₃	D ₃	N	D ₄	K ₃	Liter
18	150	200	35	230	20	55	14	8	265	255	12
22	155	175	60	270	20	60	18	10	310	285	24
26	205	210	50	310	25	70	22	10	335	310	43
32	220	245	75	370	30	90	26	10	335	350	70
38	260	290	85	430	30	95	26	10	430	390	110
45	345	360	65	520	40	125	33	10	430	450	190
50	425	420	75	600	40	140	33	10	480	490	280
56	450	440	75	590	45	140	39	10	480	490	340
61	490	500	85	710	55	175	45	10	540	560	530
66	525	520	90	710	55	175	45	10	540	560	590
71	580	580	90	790	55	190	45	10	575	600	740

*Shaft Tolerance d ≤ 80 = m6
d > 80 = n6

Quadruple Reduction

Permissible Transmitting Power Ratings

UNIT : kW

Nomina Ratio	Speed		Gear Unit Size									
	Input rpm	Output rpm	22	26	32	38	45	50	56	61	66	71
112	1800	16	27	44	76	132	210	296	363	545	620	824
	1200	11	18	29	51	88	140	197	242	363	414	550
	900	8	13	22	38	66	105	148	181	272	310	412
125	1800	14	23	37	61	110	171	261	319	485	546	735
	1200	10	15	25	41	74	113	174	213	323	364	489
	900	7	11	18	31	55	85	130	160	242	273	367
140	1800	13	21	32	54	97	227	235	283	446	462	650
	1200	9	14	21	36	65	101	157	188	298	308	433
	900	6	11	16	27	48	76	117	141	223	231	325
160	1800	11	19	28	52	92	136	209	250	390	419	580
	1200	8	13	19	35	62	90	139	167	260	280	386
	900	6	9	14	26	46	68	104	125	195	210	290
180	1800	10	17	26	46	84	131	186	227	302	371	524
	1200	7	11	17	30	55	87	124	151	201	247	350
	900	5	8	13	23	42	66	92	113	151	186	262
200	1800	9	15	23	41	75	121	169	210	280	362	475
	1200	6	10	15	27	50	81	112	140	186	242	317
	900	5	7	11	20	37	60	84	105	140	181	237
224	1800	8	13	22	37	67	108	136	157	240	315	422
	1200	5	9	15	25	45	72	90	105	160	210	281
	900	4	7	11	18	34	54	68	79	120	157	211
250	1800	7	12	20	35	60	98	134	161	251	283	341
	1200	5	8	13	23	40	65	89	107	167	189	227
	900	4	6	10	17	30	49	67	81	125	142	171
280	1800	6	11	19	32	52	86	119	144	228	248	309
	1200	4	7	12	21	35	57	80	95	152	166	207
	900	3	5	9	16	26	43	60	72	114	124	155
315	1800	6	10	16	28	47	76	107	130	201	218	292
	1200	4	6	11	19	31	51	72	87	134	145	195
	900	3	5	8	14	24	38	54	65	101	109	146
355	1800	5	9	14	25	41	69	96	121	178	194	267
	1200	3	6	10	17	28	46	64	81	119	130	178
	900	3	4	7	13	21	34	48	60	89	97	133
400	1800	5	7	13	22	37	60	82	107	158	177	237
	1200	3	5	9	15	25	40	54	72	106	119	158
	900	2	4	6	11	19	30	41	54	79	89	119
450	1800	4	7	12	20	34	54	73	91	142	161	204
	1200	3	5	8	13	22	36	48	61	94	107	136
	900	2	3	6	10	16	27	37	45	71	81	102
500	1800	4	6	10	18	31	49	66	84	125	143	187
	1200	2	4	7	12	20	33	45	56	84	95	125
	900	2	3	5	9	15	25	34	42	63	72	93

Thermal Ratings

UNIT : kW

Ratio	Speed		Unit Size									
	Input rpm		22	26	32	38	45	50	56	61	66	71
112 - 280	1800		47	65	92	128	181	232	257	337	367	435
	1200		44	61	86	120	170	218	241	316	345	409
	900		41	57	80	112	159	204	226	297	324	384
315 - 500	1800		42	58	83	115	163	209	231	304	331	393
	1200		39	54	78	108	153	196	217	285	311	369
	900		37	51	74	103	146	188	208	273	298	353
112 - 280	1800		64	89	126	175	247	317	352	461	502	597
	1200		59	82	117	162	229	294	326	427	465	553
	900		54	76	108	150	213	273	303	397	432	514
315 - 500	1800		59	82	117	162	229	294	327	428	466	555
	1200		53	74	106	147	208	267	297	389	424	505
	900		49	69	98	136	193	248	276	362	394	469

Permissible Torque Ratings / WR2

UNIT : kW

	Nominal Ratio	Unit Size										
		22	26	32	38	45	50	56	61	66	71	
Permissible Torque Ratings (UNIT : kgm)	112	1603	2617	4523	7835	12553	17628	21634	32496	37036	49144	
	125	1520	2464	4074	7353	11327	17389	21264	32293	36367	48887	
	140	1580	2382	4029	7234	11351	17472	21033	33275	34499	48521	
	160	1603	2404	4439	7885	11574	17806	21367	33195	35739	49475	
	180	1603	2461	4378	8013	12591	17742	21749	29046	35628	50365	
	200	1574	2448	4324	7949	12878	17965	22416	29889	38633	50556	
	224	1585	2671	4398	8013	12998	16203	18874	28668	37571	50391	
	250	1669	2703	4650	7949	13116	17885	21463	33386	37758	45508	
	280	1603	2782	4763	7790	12909	17806	21367	34054	36947	46295	
	315	1603	2679	4732	8013	12770	18029	21784	33803	36558	49078	
	355	1637	2709	4741	7901	12981	18343	22858	33581	36685	50512	
	400	1558	2766	4801	7949	12719	17488	22893	33704	37838	50556	
	450	1645	2754	4722	7870	12878	17528	21820	33982	38633	49006	
	500	1590	2742	4690	7949	13116	17885	22257	33386	38156	49682	
	Rotational Inertia WR ² (UNIT : kgm ²)	112	0.0040	0.0064	0.0170	0.0419	0.0939	0.2351	0.2409	0.5532	0.5801	1.2348
		125	0.0036	0.0054	0.0156	0.0353	0.0846	0.2046	0.2176	0.4681	0.4898	1.1130
		140	0.0034	0.0046	0.0144	0.0305	0.0776	0.1841	0.1998	0.3998	0.4172	1.0045
		160	0.0032	0.0038	0.0134	0.0259	0.0716	0.1709	0.1855	0.3398	0.3552	0.9519
		180	0.0026	0.0030	0.0106	0.0211	0.0602	0.1432	0.1552	0.2884	0.3015	0.7905
		200	0.0024	0.0028	0.0106	0.0185	0.0566	0.1344	0.1452	0.2333	0.2443	0.7472
224		0.0024	0.0026	0.0106	0.0168	0.0578	0.1368	0.1482	0.225	0.2345	0.7590	
250		0.0020	0.0020	0.0084	0.0138	0.0485	0.1151	0.1242	0.1974	0.2038	0.6370	
280		0.0020	0.0016	0.0082	0.0116	0.0469	0.1119	0.1212	0.1601	0.1643	0.6174	
315		0.0016	0.0014	0.0066	0.0098	0.0375	0.0903	0.0971	0.1340	0.1374	0.4914	
355		0.0016	0.0012	0.0068	0.0094	0.0393	0.0935	0.1009	0.1256	0.1284	0.5151	
400		0.0016	0.0012	0.0066	0.0086	0.0375	0.0923	0.0997	0.1081	0.1105	0.5073	
450		0.0016	0.0012	0.0064	0.0072	0.0369	0.0891	0.0971	0.10909	0.0929	0.4954	
500		0.0012	0.0012	0.0054	0.0066	0.0311	0.0746	0.0808	0.0756	0.0772	0.4246	

Parallel Shaft (SHD)

UNIT : mm

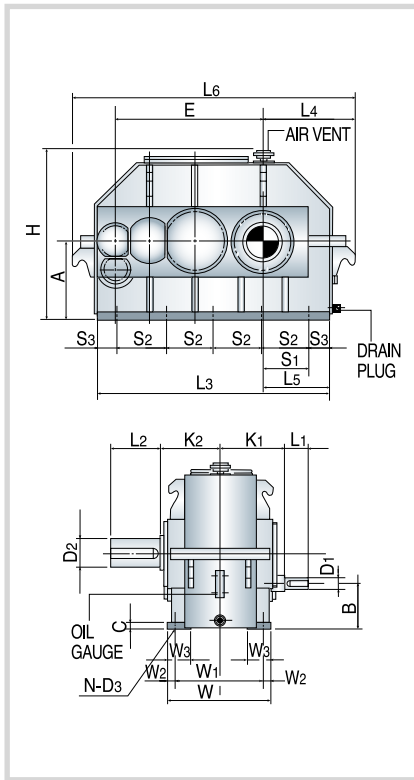

Unit Size	High Speed Shaft					
	Ratio : 112 - 280			Ratio : 315 - 500		
	D ₁	L ₁	Key	D ₁	L ₁	Key
22	22	35	6 x 6	19	35	6 x 6
26	25	40	8 x 7	20	35	6 x 6
32	32	60	10 x 8	28	50	8 x 7
38	38	60	10 x 8	30	50	8 x 7
45	45	70	14 x 9	35	60	10 x 8
50	55	90	16 x 10	42	70	12 x 8
56	60	105	18 x 11	45	70	14 x 9
61	65	105	18 x 11	50	80	14 x 9
66	70	110	20 x 12	55	90	16 x 10
71	75	120	20 x 12	60	105	18 x 11

UNIT : mm

Unit Size	Dimensions										
	E	K ₁	K ₂	L ₃	L ₁	L ₅	L ₆	A	H	W	C
22	505	190	190	810	295	215	970	250	525	160	20
26	575	220	215	930	335	255	1090	315	640	225	28
32	700	260	250	1130	395	295	1330	355	740	243	28
38	835	300	285	1310	445	345	1510	400	870	275	35
45	990	360	350	1560	530	410	1800	500	1030	340	35
50	1150	400	390	1830	620	500	2070	560	1140	375	40
56	1205	400	390	1920	655	525	2180	630	1230	445	45
61	1380	470	460	2170	705	575	2430	710	1380	490	45
66	1430	470	460	2270	745	615	2530	750	1470	530	45
71	1590	510	500	2520	800	670	2780	800	1570	535	50

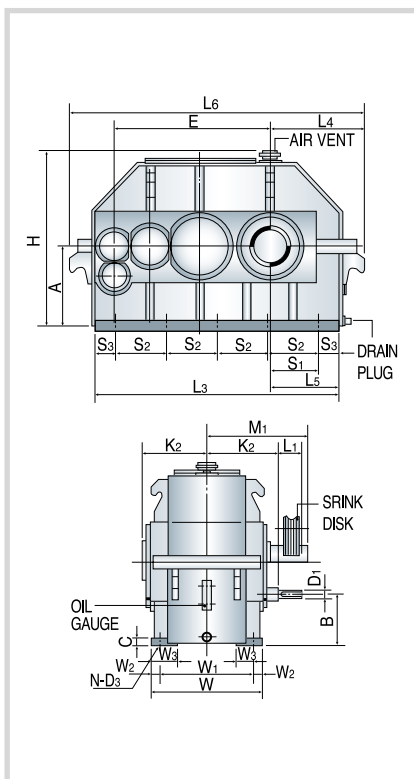

UNIT : mm

Unit Size	Low Speed Shaft				
	Solid Shaft			Hollow Shaft	
	WT(kg)	D ₂	L ₂	Key	WT(kg)
22	465	100	180	28 x 16	442
26	660	120	210	32 x 18	627
32	1200	140	240	36 x 20	1140
38	1800	170	270	40 x 22	1710
45	2800	200	350	45 x 25	2660
50	4250	220	350	50 x 28	3910
56	5150	240	400	56 x 32	4738
61	6950	270	450	63 x 32	6394
66	8030	290	450	63 x 32	7388
71	10500	310	500	70 x 36	9660

Refer to page 26 and 27
for shaft dimensions

UNIT : mm

Unit Size	Dimensions									Oil Cap.
	S ₁	S ₂	S ₃	W	W ₁	W ₂	W ₃	D ₃	N	Liter
22	160	175	55	310	270	20	60	18	10	26
26	190	200	65	360	310	25	70	22	10	45
32	230	250	65	430	370	30	90	26	10	83
38	290	300	55	490	430	30	95	26	10	155
45	330	350	80	600	520	40	125	33	10	275
50	425	420	75	680	600	40	140	33	10	380
56	445	440	80	680	590	45	140	39	10	500
61	490	500	85	820	710	55	175	45	10	560
66	520	520	95	820	710	55	175	45	10	620
71	570	580	100	900	790	55	190	45	10	940

*Shaft Tolerance d ≤ 80 = m6
d > 80 = n6

Double Reduction

Permissible Transmitting Power Ratings

UNIT : kW

Nominal Ratio	Speed		Gear Unit Size								
	Input rpm	Output rpm	18	22	26	32	38	45	50	56	61
Mechanical Power Ratings											
5.6	1800	321	174	289	434	944	1676	-	-	-	-
	1200	214	115	192	289	630	1116	1826	2504	3480	-
	900	161	86	144	216	473	840	1370	1878	2610	3622
6.3	1800	286	150	216	325	787	1448	-	-	-	-
	1200	190	100	144	216	526	966	1543	2047	2936	-
	900	143	76	108	162	394	725	1158	1536	2202	3072
7.1	1800	254	174	289	434	944	1676	-	-	-	-
	1200	169	115	192	289	630	1117	1826	2504	3480	-
	900	127	86	144	216	473	840	1370	1878	2610	3622
8	1800	225	150	216	325	787	1448	-	-	-	-
	1200	150	100	144	216	526	966	1543	2047	2936	-
	900	113	76	108	162	394	725	1158	1536	2202	3072
9	1800	200	150	216	325	787	1448	-	-	-	-
	1200	133	100	144	216	526	966	1543	2047	2630	-
	900	100	76	108	162	394	725	1158	1536	1973	3072
10	1800	180	120	174	312	594	1070	1934	-	-	-
	1200	120	79	115	206	396	638	1291	1638	2332	-
	900	90	60	86	155	296	535	968	1229	1748	2363
11.2	1800	161	92	138	252	506	984	1512	1914	-	-
	1200	107	60	90	168	337	656	1008	1277	2016	2834
	900	80	46	67	126	252	492	756	958	1512	2126
12.5	1800	144	84	120	205	473	780	1236	1638	-	-
	1200	96	55	79	137	314	521	824	1092	1654	2252
	900	72	42	60	103	236	390	618	818	1241	1690
14	1800	129	84	120	205	473	780	1236	1638	-	-
	1200	86	55	79	137	314	521	824	1092	1550	2252
	900	64	42	60	103	236	390	618	818	1164	1690
16	1800	113	70	98	181	354	630	968	1402	1866	-
	1200	75	47	66	120	235	420	646	936	1243	1795
	900	56	36	49	90	178	314	485	702	934	1346
18	1800	100	55	76	149	282	511	835	1094	1622	-
	1200	67	36	50	100	180	341	557	730	1082	1465
	900	50	28	37	74	140	256	418	548	811	1098

Thermal Ratings

UNIT : kW

Nominal Ratio	Speed		Unit Size								
	Input rpm		18	22	26	32	38	45	50	56	61
Without Auxiliary Cooling											
5.6 - 11.2	1800		58	79	113	161	207301	370	438	552	
	1200		56	76	108	155	199290	356	423	531	
	900		53	72	103	146	188274	336	399	502	
12.5 - 18	1800		54	73	104	149	192279	342	407	511	
	1200		51	70	99	141	182264	324	385	484	
	900		49	66	94	134	172251	308	366	460	
With Fan Cooling											
5.6 - 11.2	1800		102	139	197	282	362	526	647	769	966
	1200		95	129	184	263	338	491	630	717	902
	900		87	119	169	241	309	450	553	657	825
12.5 - 18	1800		94	128	183	260	335	488	599	711	895
	1200		87	118	168	239	308	448	550	654	823
	900		80	108	154	221	283	412	506	602	757

Permissible Torque Ratings / WR2

	Nominal Ratio	Unit Size								
		18	22	26	32	38	45	50	56	61
Permissible Torque Ratings (UNIT : kgm)	5.6	516	860	1289	2622	5014	8181	11121	15580	21619
	6.3	508	725	1088	2643	4868	7777	10315	14788	21358
	7.1	654	1090	1635	3578	6358	10372	14214	19754	27410
	8	645	921	1382	3357	6181	9875	13099	18778	26198
	9	725	1036	1554	3776	6954	11110	14736	18927	29472
	10	640	921	1650	3160	5705	10323	13099	18638	25187
	11.2	544	802	1504	3009	5874	9026	11433	18052	25387
	12.5	560	799	1375	3150	5197	8235	10905	16533	22514
	14	627	895	1540	3528	5820	9223	12222	17371	25215
	16	614	839	1535	3029	5362	8269	11973	15923	22964
18	530	714	1428	2694	4904	8013	10523	15565	21068	
Rotational Inertia WR ² (UNIT : kgm ²)	5.6	0.0706	0.1645	0.4639	1.1601	2.4982	5.5261	9.0766	17.4657	30.5083
	6.3	0.0610	0.1428	0.3951	1.0205	2.2210	4.8253	8.1854	15.1388	26.3525
	7.1	0.0646	0.1510	0.4204	1.0546	2.3083	4.9348	8.4640	16.0737	28.7578
	8	0.0562	0.1322	0.3602	0.9365	2.0688	4.3539	7.6944	14.0284	24.9501
	9	0.0534	0.1258	0.3386	0.9162	1.9653	4.2691	7.4031	13.5023	23.9298
	10	0.0471	0.1081	0.2902	0.8045	1.6395	3.9054	6.6134	11.7655	20.8712
	11.2	0.0363	0.0836	0.2483	0.6421	1.4925	3.2546	5.4559	10.1693	17.5345
	12.5	0.0309	0.0682	0.1964	0.5456	1.1750	2.7397	4.5798	7.9509	14.2631
	14	0.0301	0.0656	0.1911	0.5315	1.1395	2.6079	4.4103	7.8247	13.8373
	16	0.0251	0.0542	0.1623	0.4326	0.8697	1.8764	2.9359	5.9403	10.4842
18	0.0213	0.0467	0.1376	0.3632	0.7371	1.5798	2.4505	4.9663	8.7378	

UNIT : mm

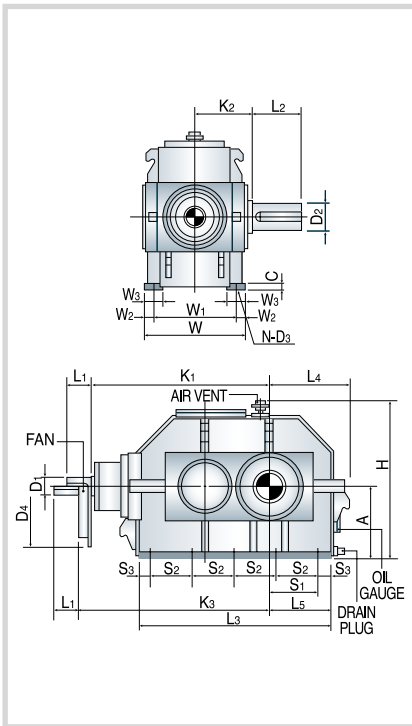

Unit Size	High Speed Shaft					
	Ratio : 5.6 - 10			Ratio : 11.2 - 18		
	D ₁	L ₁	Key	D ₁	L ₁	Key
18	45	70	14 x 9	35	60	10 x 8
22	50	80	14 x 9	40	70	12 x 8
26	60	105	18 x 11	55	90	16 x 10
32	75	120	20 x 12	70	120	20 x 12
38	90	160	25 x 14	80	140	22 x 14
45	100	180	28 x 16	90	160	25 x 14
50	110	180	28 x 16	100	180	28 x 16
56	130	210	32 x 18	110	180	28 x 16
61	140	240	36 x 20	120	210	32 x 18

UNIT : mm

Unit Size	Dimensions										
	E	K ₁	K ₂	L ₃	L ₄	L ₅	L ₆	A	H	W	C
18		540	180	560	270	190		200	452	292	20
22		620	200	690	310	230		250	561	332	20
26		715	240	790	340	260		280	640	408	28
32		890	280	940	380	300		355	765	490	28
38		1050	310	1110	450	350		400	860	530	28
45		1195	370	1315	510	410		500	1019	650	35
50		1315	400	1500	575	455		560	1119	710	35
56		1485	440	1600	620	500		630	1239	780	40
61		1630	500	1790	670	550		710	1357	900	45

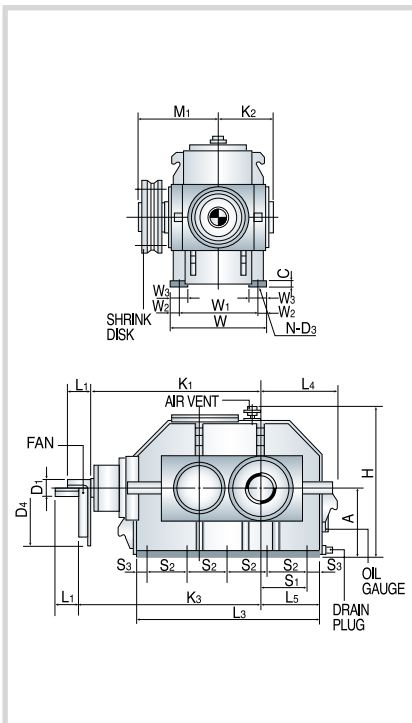

UNIT : mm

Unit Size	Low Speed Shaft					Hollow Shaft
	WT(kg)	D ₂	L ₂	Key	WT(kg)	
18	315	80	140	22 x 14	289	Refer to page 26 and 27 for shaft dimensions
22	490	100	180	28 x 16	450	
26	770	120	210	32 x 18	707	
32	1340	140	240	36 x 20	1230	
38	2015	170	270	40 x 22	1850	
45	3270	200	350	45 x 25	3002	
50	4240	220	350	50 x 28	3893	
56	5580	240	400	56 x 32	5123	
61	7450	270	450	63 x 32	6840	

UNIT : mm

Unit Size	Dimensions									Fan Cooling	Oil Cap.
	S ₁	S ₂	S ₃	W ₁	W ₂	W ₃	D ₃	N	D ₄	K ₃	Liter
18	160	125	30	260	16	56	14	10	430	630	11
22	195	155	35	290	21	66	18	10	430	710	19
26	225	180	35	355	26.5	89	22	10	480	805	28
32	250	210	50	430	30	95	26	10	575	980	55
38	305	255	45	465	32.5	100	26	10	635	1140	75
45	362.5	305	47.5	570	40	120	33	10	735	1285	150
50	385	340	70	640	35	125	33	10	735	1405	220
56	440	370	60	690	45	135	39	10	830	1575	290
61	475	410	75	800	50	155	45	10	830	1720	420

*Shaft Tolerance d ≤ 80 = m6
d > 80 = n6

Triple Reduction

Permissible Transmitting Power Ratings

UNIT : kW

Nominal Ratio	Speed		Gear Unit Size										
	Input rpm	Output rpm	18	22	26	32	38	45	50	56	61	66	71
			Mechanical Power Ratings										
20	1800	90	54	115	180	304	456	950	1484	1758	-	-	-
	1200	60	36	77	120	209	310	660	990	1170	1914	-	2622
	900	45	26	56	90	152	228	474	742	876	1434	-	1968
22.4	1800	80	54	115	180	304	456	950	1402	1650	-	-	-
	1200	54	36	77	120	209	310	660	936	1099	1732	-	2172
	900	40	26	56	90	152	228	474	700	824	1232	-	1624
25	1800	72	54	108	180	296	456	854	1178	1674	-	-	-
	1200	48	36	72	120	198	310	588	786	1116	1560	1632	2094
	900	36	26	54	90	148	228	426	588	836	1168	1224	1578
28	1800	64	54	90	168	288	456	758	1122	1302	-	-	-
	1200	43	36	60	110	192	310	522	746	869	1368	1584	1946
	900	32	26	44	84	144	228	378	560	650	1026	1188	1459
31.5	1800	57	46	82	151	228	341	690	996	1170	-	-	-
	1200	38	30	54	92	156	234	475	666	780	1230	1418	1734
	900	29	22	41	74	114	168	344	498	584	922	1064	1298
35.5	1800	51	44	72	122	228	341	650	890	1046	-	-	-
	1200	34	29	48	82	151	234	432	594	696	1112	1286	1490
	900	25	22	36	60	114	168	324	444	522	834	965	1164
40	1800	45	36	66	113	198	324	588	792	924	1484	1698	-
	1200	30	24	44	72	132	218	384	528	614	990	1133	1368
	900	23	17	32	55	98	162	312	396	462	742	848	1026
45	1800	40	28	56	96	144	264	510	701	824	1310	1518	1730
	1200	27	18	38	65	96	178	341	468	550	874	1010	1152
	900	20	13	36	48	72	132	254	348	412	654	758	864
50	1800	36	22	50	84	125	214	462	636	742	1188	1296	1650
	1200	24	14	32	58	84	142	307	422	493	792	864	1099
	900	18	11	25	42	61	108	170	317	371	594	648	824
56	1800	32	22	48	85	125	214	408	552	642	1046	1212	1468
	1200	21	14	31	56	84	142	270	422	427	696	808	978
	900	16	11	24	42	61	108	204	276	320	522	606	732
63	1800	29	17	42	73	112	188	364	486	569	924	1014	1278
	1200	19	11	28	48	73	125	242	324	378	614	676	852
	900	14	8	20	36	55	94	180	242	283	462	506	638
71	1800	25	17	36	60	100	188	265	386	468	726	924	1104
	1200	17	11	24	40	66	125	176	257	312	482	614	737
	900	13	8	17	30	50	94	132	192	235	362	462	550
80	1800	23	14	31	54	85	154	228	346	420	650	824	990
	1200	15	10	20	36	56	103	151	229	280	432	550	660
	900	11	7	16	26	42	77	114	173	210	324	412	494

Thermal Ratings

UNIT : kW

Ratio	Speed		Unit Size										
	Input rpm		18	22	26	32	38	45	50	56	61	66	71
	Without Auxiliary Cooling												
20 - 35.5	1800		42	61	83	115	155	225	290	314	425	460	546
	1200		39	57	78	108	145	210	271	293	396	430	510
	900		37	54	73	101	136	197	254	275	372	403	478
40 - 80	1800		37	54	74	102	138	199	257	278	376	408	484
	1200		35	51	70	96	130	188	242	261	354	384	455
	900		34	49	66	92	124	179	231	250	338	366	434
	With Fan Cooling												
20 - 35.5	1800		64	92	125	173	233	337	435	471	637	691	819
	1200		58	83	113	157	211	306	394	426	576	625	742
	900		52	76	103	142	192	278	358	387	523	567	673
40 - 80	1800		56	81	111	153	207	299	385	417	564	611	726
	1200		51	74	101	140	188	273	352	380	515	558	661
	900		48	69	94	129	174	252	325	352	476	516	613

Permissible Torque Ratings / WR2

	Nominal Ratio	Unit Size											
		18	22	26	32	38	45	50	56	61	66	71	
Permissible Torque Ratings (UNIT : kgm)	20	563	1202	1919	3249	4861	10106	15811	18676	30573	-	-	41957
	22.4	630	1347	2149	3639	5444	11318	16705	19685	29427	-	-	38769
	25	704	1439	2398	3933	6076	11353	15670	22290	31116	32619	-	42053
	28	788	1325	2507	4298	6805	11282	16727	19413	30624	35459	-	43554
	31.5	725	1370	2498	3828	5641	11564	16722	19623	30946	35741	-	43599
	35.5	817	1362	2271	4314	6358	12261	16802	19754	31561	36511	-	44049
	40	716	1382	2354	4196	6908	13304	16885	19699	31621	36175	-	43748
	45	633	1727	2303	3454	6332	12203	16693	19744	31372	36380	-	41446
	50	595	1343	2239	3262	5756	9082	16885	19763	31680	34538	-	43940
	56	666	1433	2507	3653	6447	12178	16476	19126	31161	36175	-	43697
	63	564	1370	2418	3707	6286	12088	16279	19019	31027	34008	-	42873
	71	636	1272	2271	3815	7084	9990	14532	17801	27428	34967	-	41597
	80	614	1330	2251	3582	6549	9722	14736	17909	27630	35101	-	42162
	Rotational Inertia WR ² (UNIT : kgm ²)	20	0.0134	0.0429	0.0846	0.1942	0.4998	1.3318	2.689	2.9714	6.4464	6.4241	10.8962
		22.4	0.0130	0.0419	0.0814	0.1916	0.4840	1.3206	2.6444	2.8797	6.2917	6.2369	10.5989
25		0.0117	0.0375	0.0732	0.1701	0.4377	1.1652	2.3847	2.6043	5.5013	5.6699	9.5846	
28		0.0115	0.0369	0.0712	0.1683	0.4276	1.1579	2.3562	2.5459	5.4028	5.5935	9.3953	
31.5		0.0100	0.0321	0.0616	0.1462	0.3669	1.0201	2.0900	2.2629	4.7366	4.8875	8.4537	
35.5		0.0095	0.0311	0.0576	0.1368	0.338	0.9810	1.955	2.1199	4.5766	4.6973	8.0101	
40		0.0079	0.0265	0.0503	0.1167	0.2888	0.8543	1.6126	1.7583	4.1873	4.2811	7.0806	
45		0.0060	0.0209	0.0389	0.0903	0.2471	0.6814	1.3886	1.5862	3.4419	3.5161	5.8254	
50		0.0051	0.0174	0.0329	0.0734	0.1952	0.5761	1.1609	1.2474	2.8831	2.9431	4.8646	
56		0.0048	0.0167	0.0317	0.0696	0.1887	0.5538	1.1150	1.1935	2.7186	2.7734	4.6322	
63		0.0040	0.0137	0.0263	0.0576	0.1611	0.4519	0.8282	0.9166	1.9729	2.0160	3.1268	
71		0.0040	0.0136	0.0263	0.0570	0.1597	0.4467	0.8212	0.9116	1.9563	2.0014	3.1086	
80	0.0027	0.0113	0.0221	0.0489	0.1356	0.3741	0.6832	0.7698	1.6381	1.6734	2.5851		

UNIT : mm

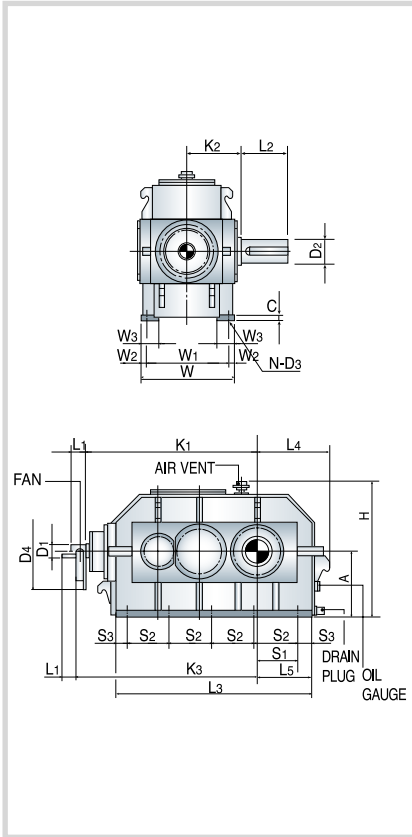

Unit Size	High Speed Shaft					
	Ratio : 12.5 - 22.4			Ratio : 71 - 112		
	D ₁	L ₁	Key	D ₁	L ₁	Key
18	28	50	8 x 7	22	35	6 x 6
22	35	60	10 x 8	28	50	8 x 7
26	45	70	14 x 9	35	60	10 x 8
32	50	80	14 x 9	40	70	12 x 8
38	60	105	18 x 11	55	90	16 x 10
45	75	120	20 x 12	70	120	20 x 12
50	80	140	22 x 14	75	120	20 x 12
56	90	160	25 x 14	80	140	22 x 14
61	100	180	28 x 16	90	160	25 x 14
66	100	180	28 x 16	90	160	25 x 14
71	110	180	28 x 16	100	180	28 x 16

UNIT : mm

Unit Size	Dimensions										
	E	K ₁	K ₂	L ₃	L ₄	L ₅	L ₆	A	H	W	C
18		580	170	630	265	185		200	445	270	20
22		685	190	780	295	215		250	525	310	20
26		805	215	890	335	255		280	640	360	28
32		940	250	1070	395	295		355	740	430	28
38		1100	285	1260	445	345		400	870	490	28
45		1340	350	1500	530	410		500	1030	600	35
50		1550	390	1760	620	500		560	1125	680	35
56		1605	390	1840	645	525		630	1230	680	40
61		1805	460	2090	715	575		710	1370	820	45
66		1855	460	2180	755	615		750	1470	820	45
71		2020	500	2420	810	670		800	1570	900	50

UNIT : mm

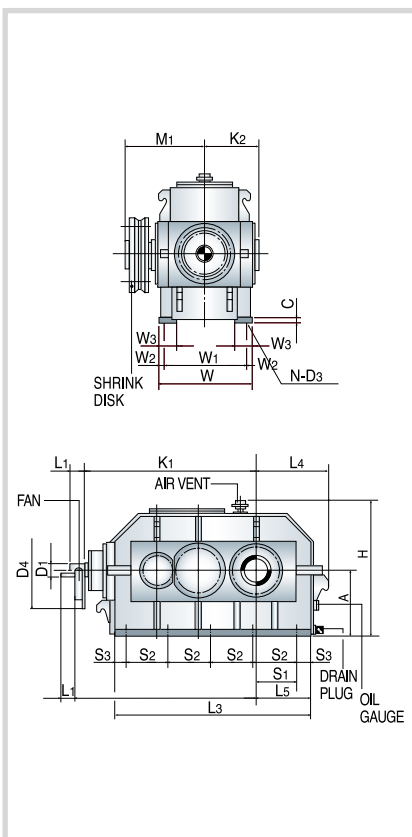

Unit Size	Low Speed Shaft					
	Solid Shaft			Hollow Shaft		
	WT(kg)	D ₂	L ₂	Key	WT(kg)	
18	305	80	140	22 x 14	280	
22	470	100	180	28 x 16	431	
26	750	120	210	32 x 18	689	
32	1160	140	240	36 x 20	1065	
38	1815	170	270	40 x 22	1666	
45	3175	200	350	45 x 25	2915	
50	4285	220	350	50 x 28	3934	
56	5035	240	400	56 x 32	4623	
61	7430	260	450	56 x 32	6821	
66	8400	280	450	63 x 32	7712	
71	10750	300	500	70 x 36	9869	

Refer to page 26 and 27 for shaft dimensions

UNIT : mm

Unit Size	Dimensions								Fan Cooling	Oil Cap.	
	S ₁	S ₂	S ₃	W ₁	W ₂	W ₃	D ₃	N			
18	140	180	45	230	20	55	14	8	310	670	12
22	155	165	60	270	20	60	18	10	335	775	24
26	190	190	65	310	25	70	22	10	430	895	41
32	220	230	75	370	30	90	26	10	430	1030	65
38	255	270	90	430	30	95	26	10	480	1190	100
45	340	340	70	520	40	125	33	10	575	1430	180
50	420	400	80	600	40	140	33	10	635	1640	270
56	445	420	80	590	45	140	39	10	735	1695	330
61	490	480	85	710	55	175	45	10	735	1895	500
66	525	500	90	710	55	175	45	10	735	1945	560
71	580	560	90	790	55	190	45	10	735	2110	720

*Shaft Tolerance d ≤ 80 = m6
d > 80 = n6

Quadruple Reduction

Permissible Transmitting Power Ratings

UNIT : kW

Nominal Ratio	Speed		Gear Unit Size									
	Input rpm	Output rpm	22	26	32	38	45	50	56	61	66	71
			Mechanical Power Ratings									
80	1800	23	34	58	94	154	286	404	483	761	877	1059
	1200	15	23	38	63	103	190	269	322	508	585	706
	900	11	17	29	47	77	142	202	242	381	438	529
90	1800	20	27	42	72	107	224	350	413	676	784	927
	1200	13	18	28	48	72	149	233	276	451	509	618
	900	10	13	21	36	54	112	174	207	338	382	463
100	1800	18	27	42	72	107	225	333	391	616	716	773
	1200	12	18	28	48	72	151	221	261	411	477	515
	900	9	13	21	36	54	113	166	196	308	358	387
112	1800	16	25	42	70	108	202	279	396	553	579	746
	1200	11	17	28	47	72	135	186	264	369	386	497
	900	8	12	21	35	54	101	139	198	277	289	374
125	1800	14	21	40	68	108	180	265	309	487	564	693
	1200	10	14	27	46	72	120	177	206	324	376	462
	900	7	11	20	34	54	90	133	154	243	282	347
140	1800	13	19	36	54	81	164	237	279	440	508	620
	1200	9	13	24	36	54	110	158	186	293	339	413
	900	6	10	18	27	40	82	119	139	220	254	310
160	1800	11	17	29	53	80	153	210	245	392	453	538
	1200	8	11	19	36	53	101	139	163	262	303	359
	900	6	9	14	27	40	76	104	123	196	227	269
180	1800	10	16	26	47	76	139	186	218	350	400	483
	1200	7	10	17	31	51	92	125	145	233	267	322
	900	5	8	13	23	38	69	93	109	174	200	242
200	1800	9	14	23	34	63	122	167	197	312	362	412
	1200	6	9	15	23	42	81	111	131	208	241	274
	900	5	7	11	17	31	61	84	98	156	181	206
224	1800	8	12	20	30	51	110	150	175	281	306	391
	1200	5	8	13	20	34	73	100	117	187	204	260
	900	4	6	10	15	25	54	75	88	140	153	195
250	1800	7	11	20	30	51	97	131	152	248	288	348
	1200	5	7	13	20	34	65	87	101	166	192	232
	900	4	6	10	15	25	48	66	76	124	144	174
280	1800	6	10	17	26	48	87	116	135	220	242	305
	1200	4	6	11	18	30	58	78	90	147	161	204
	900	3	5	9	13	22	43	58	68	110	121	152
315	1800	6	8	14	24	45	63	92	112	173	221	263
	1200	4	6	9	16	30	42	61	75	116	147	176
	900	3	4	7	12	22	31	46	56	87	110	132
355	1800	5	8	13	20	37	54	83	100	155	197	236
	1200	5	5	9	13	25	37	55	67	103	131	157
	900	3	4	6	10	19	27	41	50	78	98	119

Thermal Ratings

UNIT : kW

Ratio	Speed Input rpm	Unit Size									
		22	26	32	38	45	50	56	61	66	71
			Without Auxiliary Cooling								
80 - 200	1800	41	56	81	110	156	200	222	291	317	376
	1200	38	52	73	102	145	187	207	272	296	351
	900	35	49	68	96	136	176	194	256	278	330
224 - 355	1800	36	50	70	98	139	178	198	259	282	335
	1200	33	47	66	92	130	167	186	243	265	315
	900	31	45	63	87	124	159	177	232	253	300
			With Fan Cooling								
80 - 200	1800	62	84	119	166	235	302	335	438	478	567
	1200	56	76	108	150	213	279	304	399	434	515
	900	51	69	98	136	193	249	276	363	394	468
224 - 355	1800	55	74	105	147	209	268	298	390	425	504
	1200	50	67	95	133	190	243	271	354	386	458
	900	46	62	87	123	175	224	250	327	356	423

Permissible Torque Ratings / WR2

	Nominal Ratio	Unit Size										
		22	26	32	38	45	50	56	61	66	71	
Permissible Torque Ratings (UNIT : kgm)	80	1437	2461	4013	6550	12146	17234	20604	32496	37392	45151	
	90	1295	2025	3441	5151	10731	16741	19817	32408	36629	44427	
	100	1447	2265	3855	5803	12003	17726	20827	32830	38156	41256	
	112	1514	2528	4175	6410	12019	17682	23682	33030	34544	44604	
	125	1431	2663	4561	7254	12023	17687	20568	32392	37559	46204	
	140	1447	2660	4073	6010	12242	17695	20811	32830	37838	46295	
	160	1450	2442	4553	6868	12973	17806	20986	33450	38664	45914	
	180	1502	2504	4464	7297	13307	17885	20890	33482	38346	46359	
	200	1463	2448	3688	6677	13036	17806	20986	33227	38633	43879	
	224	1407	2350	3543	6054	12998	17984	21011	33475	36502	46473	
	250	1471	2683	3975	6757	12917	17488	20270	32989	38354	46502	
	280	1447	2560	3940	6677	12909	17361	20254	32941	36057	46405	
	315	1402	2379	4006	7512	10517	15525	18790	29046	37059	44320	
	355	1411	2427	3838	7055	10159	15521	18907	29348	37249	44869	
	Rotational Inertia WR ² (UNIT : kgm ²)	80	0.0085	0.0166	0.0215	0.0465	0.1149	0.2684	0.3153	0.6431	0.7768	0.9939
		90	0.0042	0.0080	0.0187	0.0403	0.0995	0.2323	0.2728	0.5562	0.6719	0.8597
100		0.0032	0.0062	0.0162	0.0391	0.0967	0.2255	0.2648	0.5396	0.6519	0.8340	
112		0.0031	0.0060	0.0156	0.0379	0.0937	0.2186	0.2567	0.5233	0.6322	0.8089	
125		0.0026	0.0052	0.0138	0.0337	0.0832	0.1946	0.2285	0.4657	0.5626	0.7199	
140		0.0026	0.0050	0.0139	0.0325	0.0806	0.1885	0.2214	0.4517	0.5456	0.6982	
160		0.0022	0.0042	0.0116	0.0281	0.0700	0.1639	0.1926	0.3925	0.4746	0.6073	
180		0.0020	0.0038	0.0064	0.0255	0.0650	0.1522	0.1629	0.3653	0.4436	0.5648	
200		0.0016	0.0030	0.0088	0.0211	0.0538	0.1262	0.1484	0.3031	0.3763	0.4687	
224		0.0012	0.0024	0.0070	0.0168	0.0429	0.1009	0.1187	0.2423	0.2928	0.3749	
250		0.0008	0.0020	0.0058	0.0136	0.0355	0.0836	0.0985	0.2010	0.2429	0.3111	
280		0.0006	0.0016	0.0054	0.0126	0.0333	0.0784	0.0925	0.1885	0.2283	0.2922	
315		0.0004	0.0012	0.0044	0.0104	0.0275	0.0650	0.0766	0.1564	0.1885	0.2425	
355		0.0002	0.0012	0.0042	0.0098	0.0263	0.0624	0.0732	0.1484	0.1805	0.2327	

UNIT : mm

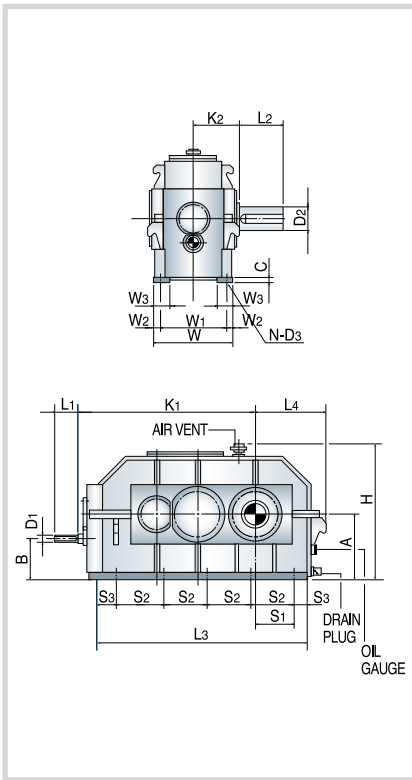

Unit Size	High Speed Shaft					
	Ratio : 80 - 200			Ratio : 224 - 355		
	D ₁	L ₁	Key	D ₁	L ₁	Key
22	24	40	8 x 7	22	35	6 x 6
26	32	55	10 x 8	28	50	8 x 7
32	32	55	10 x 8	28	50	8 x 7
38	42	70	12 x 8	32	60	10 x 8
45	48	80	14 x 9	38	60	10 x 8
50	55	90	16 x 10	42	70	12 x 8
56	60	105	18 x 11	42	70	12 x 8
61	65	105	18 x 11	48	80	14 x 9
66	75	120	20 x 12	60	105	18 x 11
71	90	160	25 x 14	65	105	18 x 11

UNIT : mm

Unit Size	Dimensions										
	E	K ₁	K ₂	L ₃	L ₄	L ₅	A	H	B	W	C
22		690	190	850	295	215	250	525	160	310	20
26		810	215	1010	335	255	315	640	203	360	28
32		950	250	1190	395	295	355	740	230	430	28
38		1110	285	1400	445	345	400	870	240	490	28
45		1330	350	1680	530	410	500	1030	315	600	35
50		1535	390	1970	620	500	560	1125	340	680	35
56		1590	390	2050	645	525	630	1230	410	680	40
61		1810	460	2310	715	575	710	1370	445	820	45
66		1860	460	2400	755	615	750	1470	485	820	45
71		2025	500	2610	810	670	800	1570	480	900	50

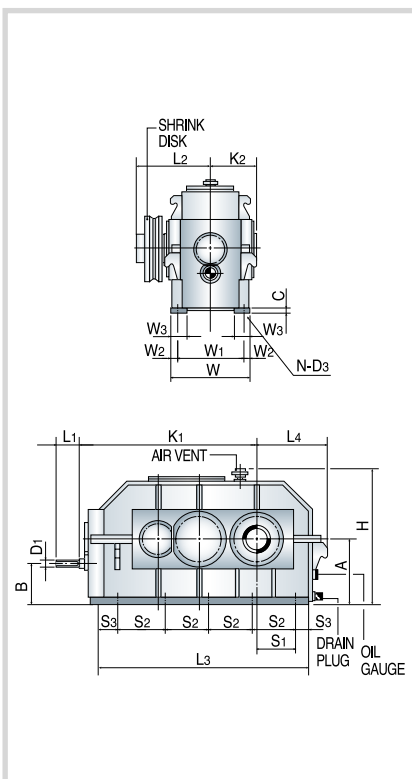

UNIT : mm

Unit Size	Low Speed Shaft					
	Solid Shaft				Hollow Shaft	
	WT(kg)	D ₂	L ₂	Key	WT(kg)	
22	480	100	180	28 x 16	441	
26	690	120	210	32 x 18	635	
32	1260	140	240	36 x 20	1159	
38	1800	170	270	40 x 22	1656	
45	3100	200	350	45 x 25	2852	
50	4500	220	350	50 x 28	4140	
56	5300	240	400	56 x 32	4876	
61	7300	270	450	63 x 32	6716	
66	8000	280	450	63 x 32	7360	
71	10500	310	500	70 x 36	9660	

Refer to page 26 and 27
for shaft dimensions

UNIT : mm

Unit Size	Dimensions									Oil Cap.
	S ₁	S ₂	S ₃	W ₁	W ₂	W ₃	D ₃	N		Liter
22	105	210	110	270	20	60	14	8		38
26	150	200	105	310	25	70	22	10		57
32	200	250	95	370	30	90	26	10		98
38	245	300	100	430	30	95	26	10		165
45	290	360	120	520	40	125	33	10		310
50	355	420	145	600	40	140	33	10		400
56	400	450	125	590	45	140	39	10		500
61	440	510	135	710	55	175	45	10		570
66	475	530	140	710	55	175	45	10		600
71	505	570	165	790	55	190	45	10		900

*Shaft Tolerance d ≤ 80 = m6
d > 80 = n6

Low Speed Overhung Loads

Low Speed Overhung Loads

UNIT : kg

Unit Size	Low Speed Shaft R.P.M							
	20	40	60	80	100	150	200	250
18	3942	3942	3942	3429	3071	2472	2082	1792
22	5770	5770	4899	4119	3502	3502	3198	2748
26	7108	6101	4921	4259	3529	3529	3302	3175
32	10002	8750	7498	6151	5298	4898	4082	3379
38	13000	11449	9789	7498	5702	4999	4999	4999
45	13898	13898	12501	8750	6999	6500	6001	-
50	18080	18080	13998	11970	8001	6999	-	-
56	19999	19999	14501	13000	8500	7979	-	-
61	21999	19187	15998	13499	8999	-	-	-
66	23002	21500	17001	13998	9498	-	-	-
71	24997	22199	17998	14501	10501	-	-	-

*NOTE : Overhung load value for worst condition.
 Allowable overhung loads acting at the center of the standard shaft extension.
 Overhung loads for 20 RPM and below use 20 RPM value.

Hollow Shaft Design with Keyway

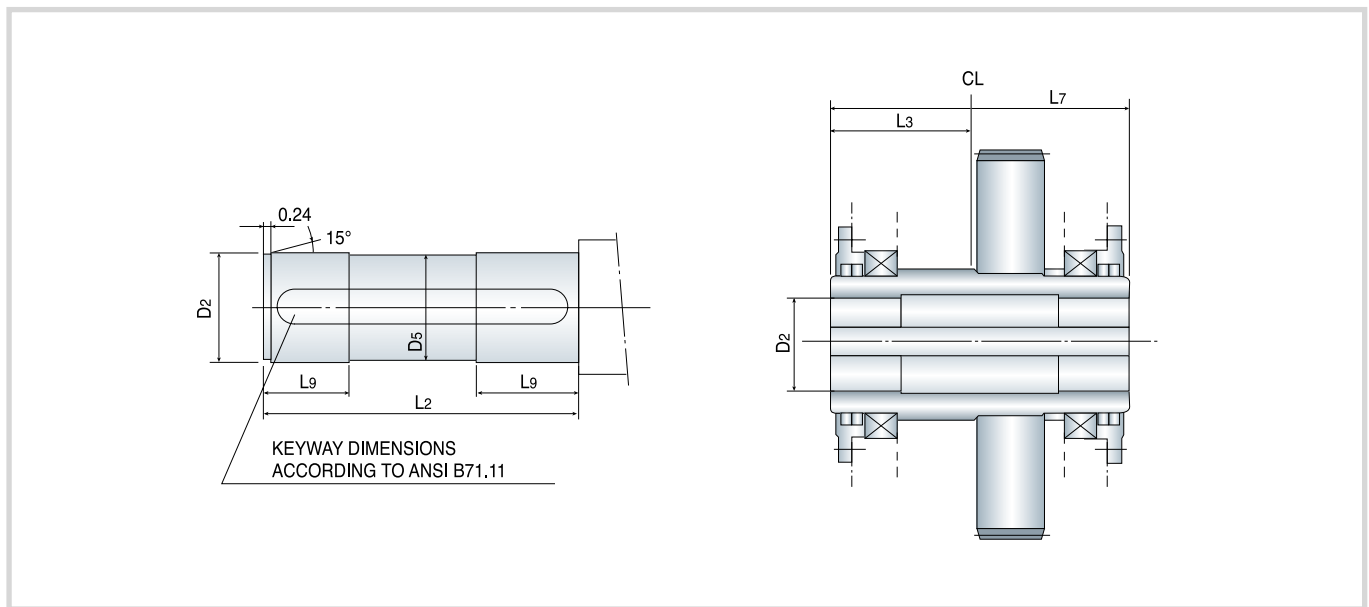

UNIT : mm

Unit Size	Double Reduction						Triple/Quadruple Reduction					
	D ₂	L ₂	L ₇	L ₃	L ₉	D ₅	D ₂	L ₂	L ₇	L ₃	L ₉	D ₅
18	90	357	360	180	85	87	90	337	340	170	85	87
22	110	397	400	200	115	107	110	377	380	190	115	107
26	130	477	480	240	130	127	130	427	430	215	130	127
32	155	557	560	280	150	152	156	155	500	250	150	152

Hollow Shaft Design

Hollow Shaft Design with Shrink Disk

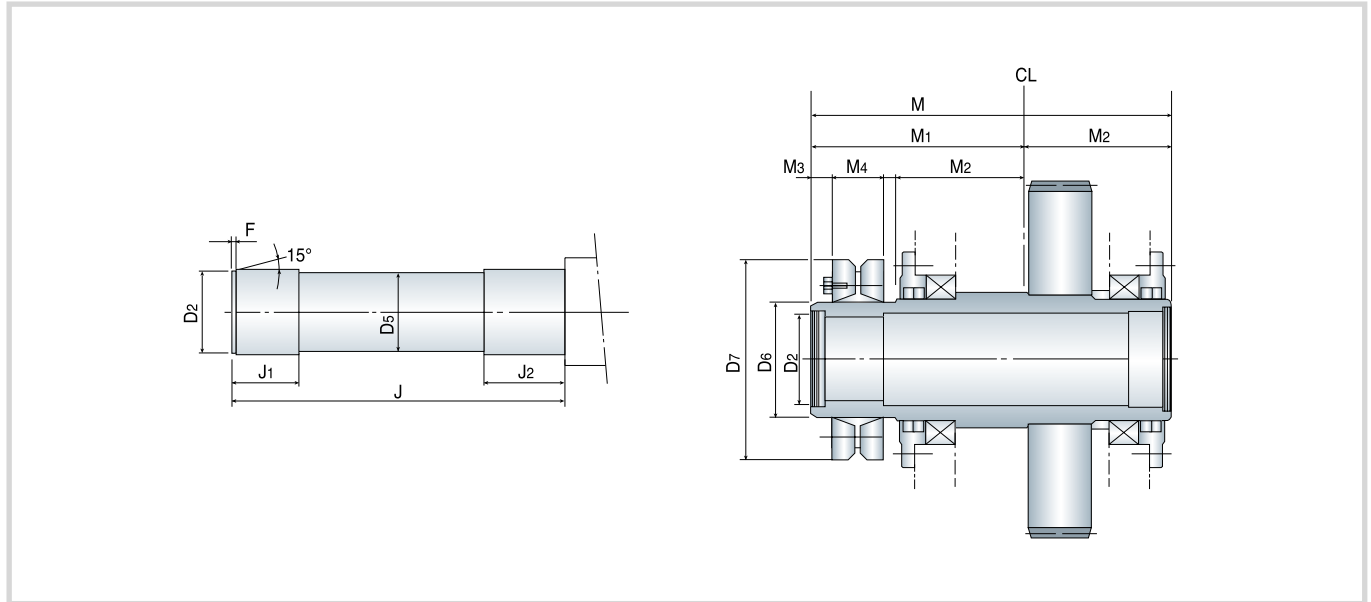

Double Reduction

UNIT : mm

Unit Size	Hollow Shaft						Shrink Disk							
	D ₂	J	J ₁	J ₂	D ₅	F	M	M ₁	M ₂	M ₃	M ₄	D ₆	D ₇	
18	90	440	75	115	87	5	455	275	180	30	54	125	215	
22	110	490	85	120	107	5	510	310	200	35	64	155	265	
26	130	575	95	135	127	5	600	360	240	37	71	175	300	
32	155	675	120	160	152	5	700	420	280	38	86	200	350	
38	200	775	135	180	197	5	800	490	310	45	120	260	430	
45	220	905	155	200	217	9	940	570	370	48	134	280	460	
50	280	995	240	290	277	9	1040	640	400	60	162	350	580	
56	310	1090	260	310	307	9	1135	695	440	67	168	390	660	
61	340	1235	275	330	337	12	1280	780	500	70	188	420	690	
66	350	1275	290	340	347	12	1320	810	510	72	202	440	750	
71	370	1370	305	350	367	12	1420	860	560	73	202	460	770	

Triple / Quadruple Reduction

UNIT : mm

Unit Size	Hollow Shaft						Shrink Disk							
	D ₂	J	J ₁	J ₂	D ₅	F	M	M ₁	M ₂	M ₃	M ₄	D ₆	D ₇	
18	90	420	75	115	87	5	435	265	170	30	54	125	215	
22	110	470	85	120	107	5	490	300	190	35	64	155	265	
26	130	525	95	135	127	5	550	335	215	37	71	175	300	
32	155	615	120	160	152	5	640	390	250	38	86	200	350	
38	200	725	135	180	197	5	750	465	285	45	120	260	430	
45	220	865	155	200	217	9	900	550	350	48	134	280	460	
50	280	975	240	290	277	9	1020	630	390	60	162	350	580	
56	310	990	260	310	307	9	1035	645	390	67	168	390	660	
61	340	1155	275	330	337	12	1200	740	460	70	188	420	690	
66	350	1175	290	340	347	12	1220	760	460	72	202	440	750	
71	370	1250	305	350	367	12	1300	800	500	73	202	460	770	

*NOTE : All data throughout the catalog subject to change without notice.



2011. 07

www.hyosungpni.com

EASE TO CONTACT TEL : 82-2-707-6181
FAX : 82-2-707-6117



HYOSUNG CORPORATION

Power & Industrial Systems Performance Group

HEAD OFFICE

450, Gongdeok-dong, Mapo-gu, Seoul, Korea
TEL : 82-2-707-6114 FAX : 82-2-714-0707

LOS ANGELES OFFICE

Hyosung America, Inc. L.A. Branch
18000 Studebaker Road, Suite 550, Cerritos Ca-90703, U.S.A.
TEL : 1-562-809-8851 FAX : 1-562-809-5251 / Mr. Ellis Chong

TOKYO OFFICE

Hyosung Japan, Co. Ltd.
SVAX TT Bldg., 11-15, 3-chome, Toranomom, Minato-ku, Tokyo, 105 Japan
TEL : 81-3-3432-9317 FAX : 81-3-3459-9300 / Mr. D. Watarai